



***Advancing the Promise of
Turkey in the Global Economy:
The Strategic Imperatives***

Partha S Ghosh

November 8th 2006

Three Essential Points:

- 1. The Current World Disorder: *The Potential Role Turkey Could Play ?***
- 2. Securing Superior Economic Stature: *Toward Enhanced Global Influence?***
- 3. Stimulating Innovation & Globalization through *targeted Growth Platforms ?***

Three Essential Points:

- 1. The Current World Disorder: *The Potential Role Turkey Could Play ?***
- 2. Securing Superior Economic Stature: *Toward Enhanced Global Influence?***
- 3. Stimulating Innovation & Globalization through *targeted Growth Platforms ?***

The *World Disorder*

Changed Equations of Power:

1. One Super power with no clear value proposition/*Eroding Trust & No Counter balance*
2. Shift in Economic Center of Gravity: *AP versus Atlantic*
3. New Economic Power of *OPEC/Uncertainties in the Energy Sector*
4. Middle East's search for a *New Identity ?*
5. Expanding EU = *New Possibilities?/New Groupings?*

Geo-Political Alliances are In Transition

Paradigm Shift

Past

Future

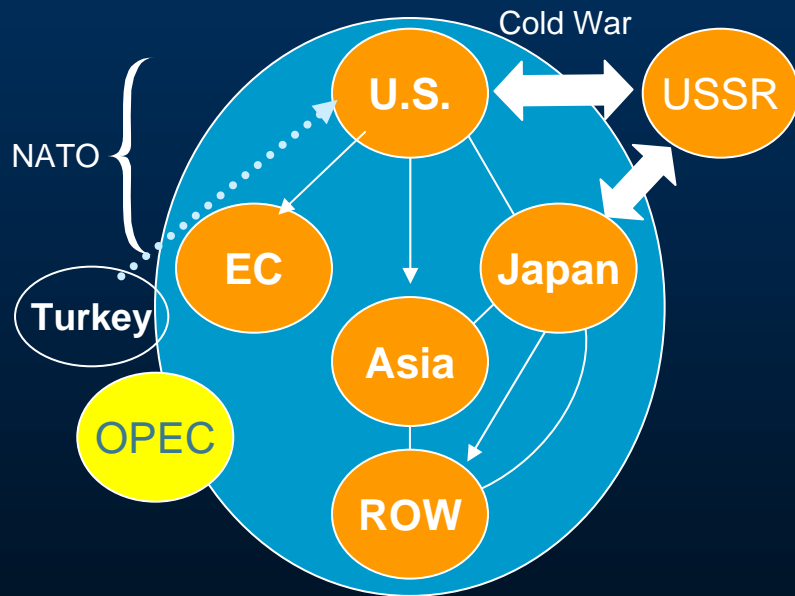

Bond by Cold War Forces of Alliances

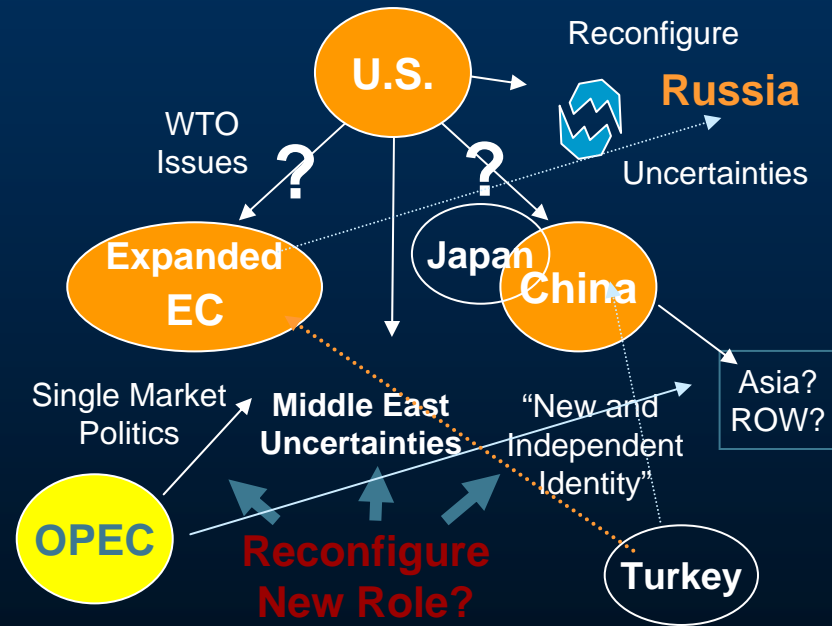

Deconstruction of Past Geopolitical Architecture

The Emerging Economic Environment will be influenced by several fundamental forces

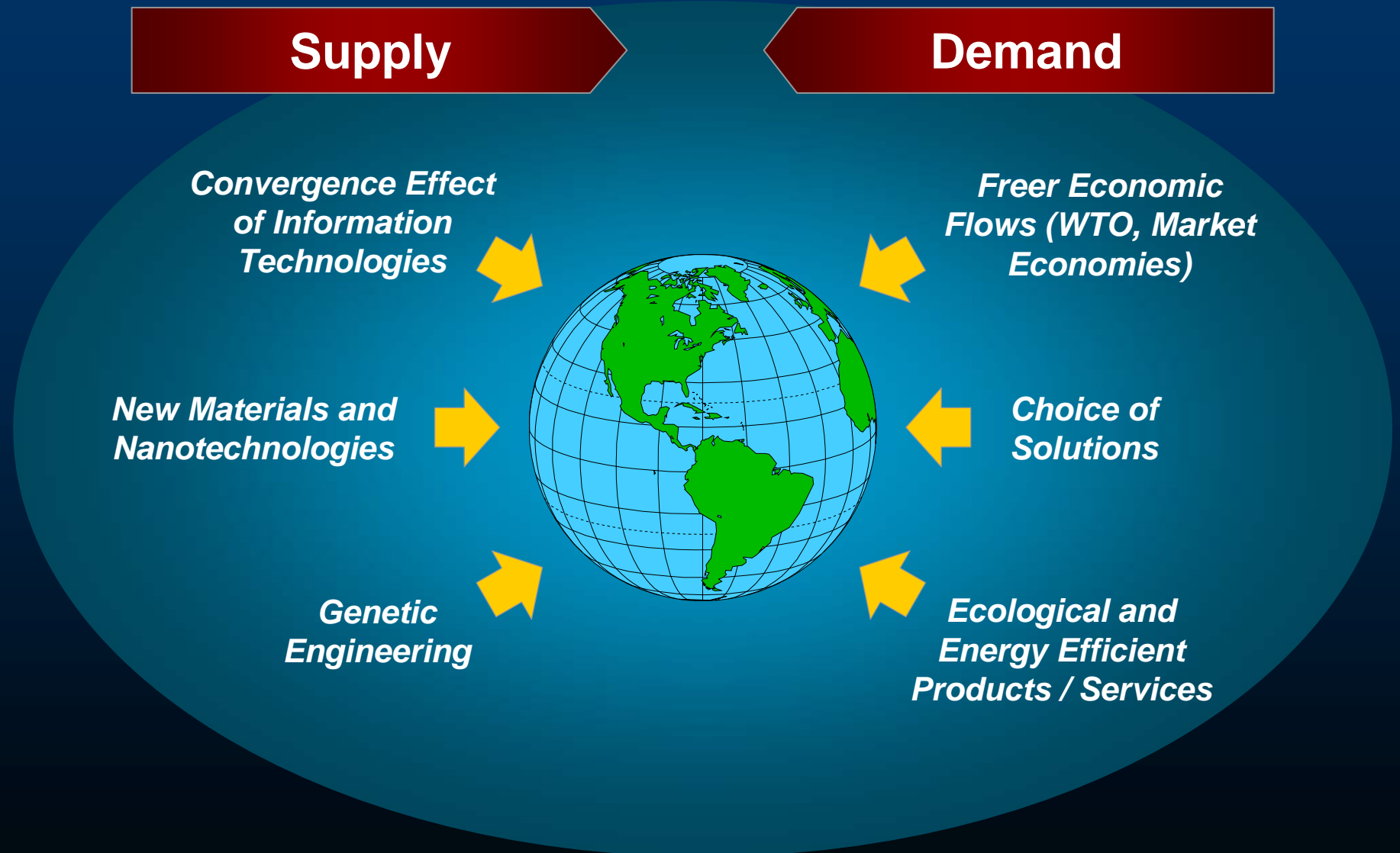

In the process several industries critical to the Nation could under-go major changes

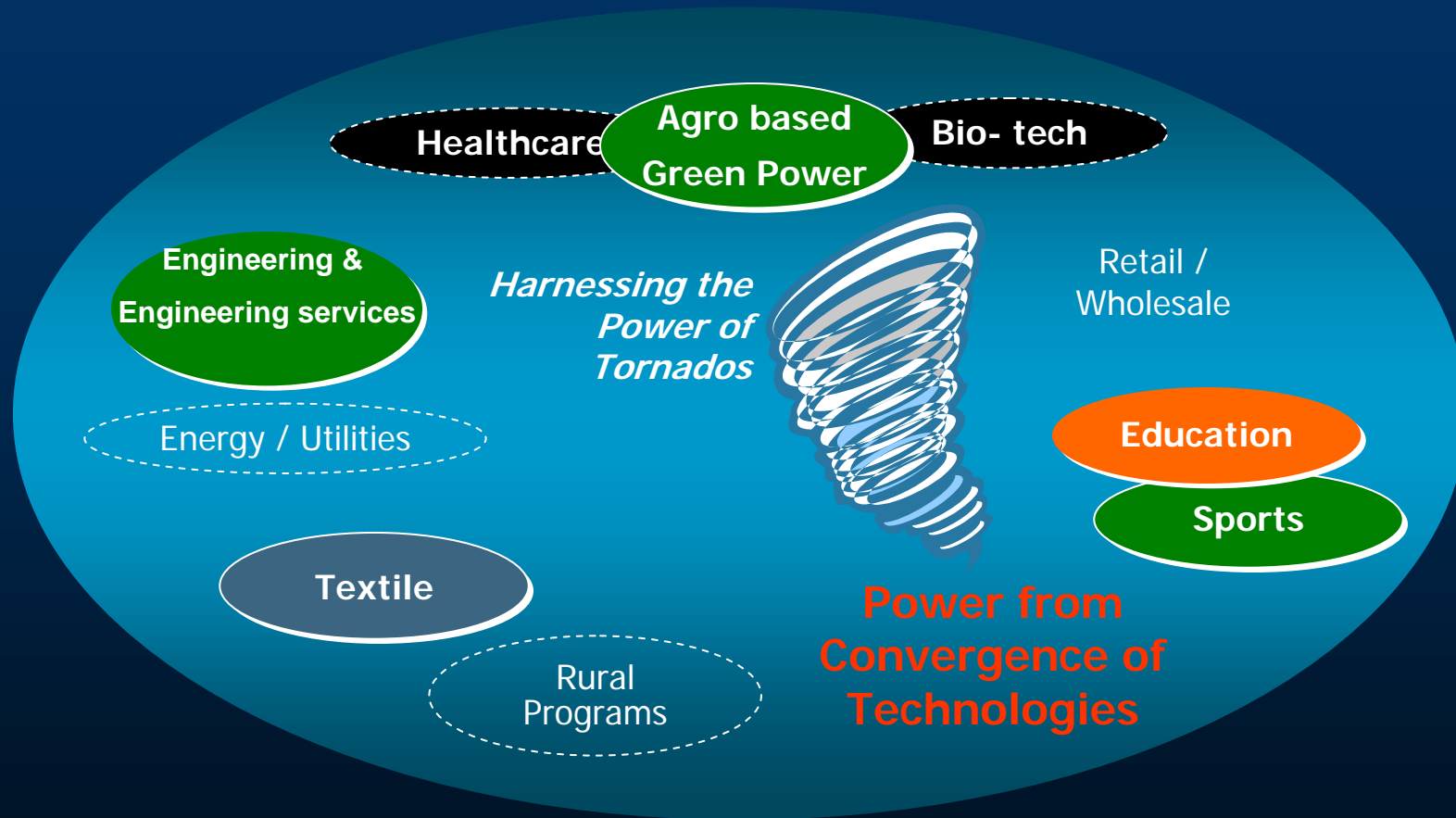

Turkey need to understand how the Tornado will change character of different industries

As a result Turkey has to make a switch from Classical to *Knowledge Economics*

Classical and Keynesian Economics

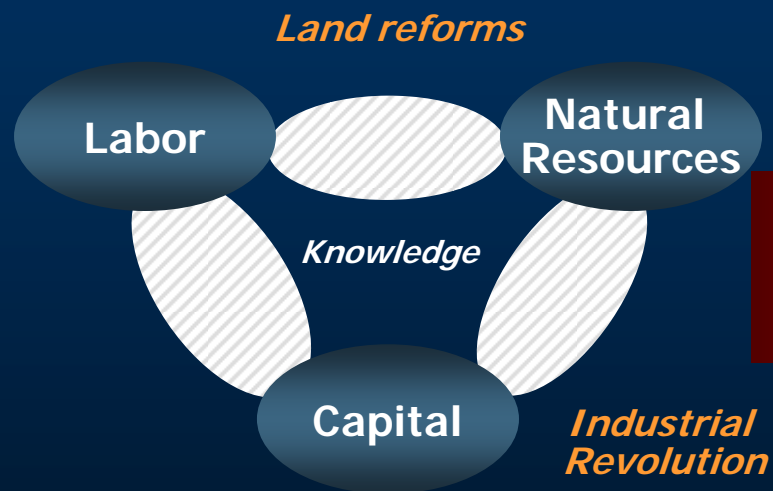

Switch

New Economic Paradigm

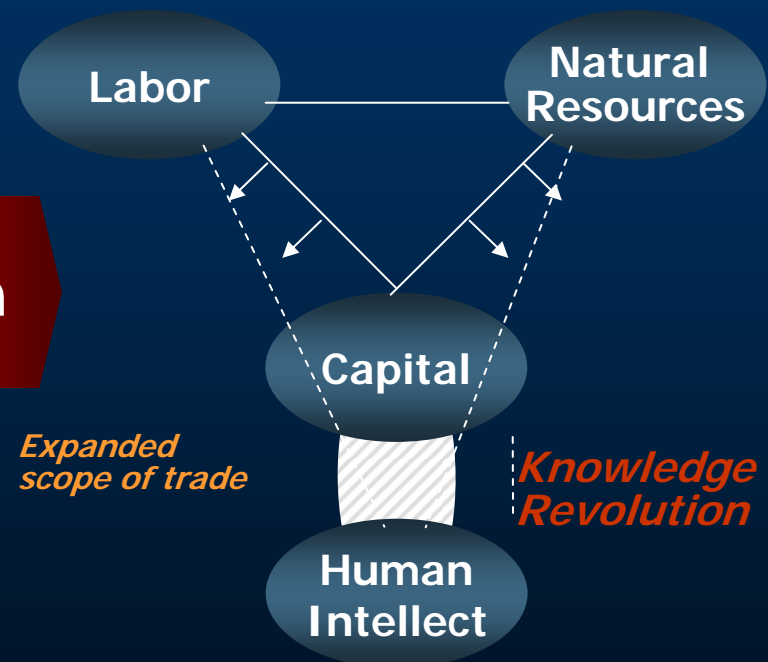

At the same time Center of Gravity of Global Economy is also shifting

Percent of GDP Distribution



Role of Turkey?

In the last quarter century Turkey has addressed some of the fundamentals



1. Stabilizing democracy
2. Harnessing Inflation
3. Strengthening Turkey's overall economic infrastructure
4. Partial Modernization of the Corporate Sector

Turkey's foreign exchange reserves increased three folds in the last ten years

Foreign Exchange Reserves in US\$ Mn (1996-2005)¹

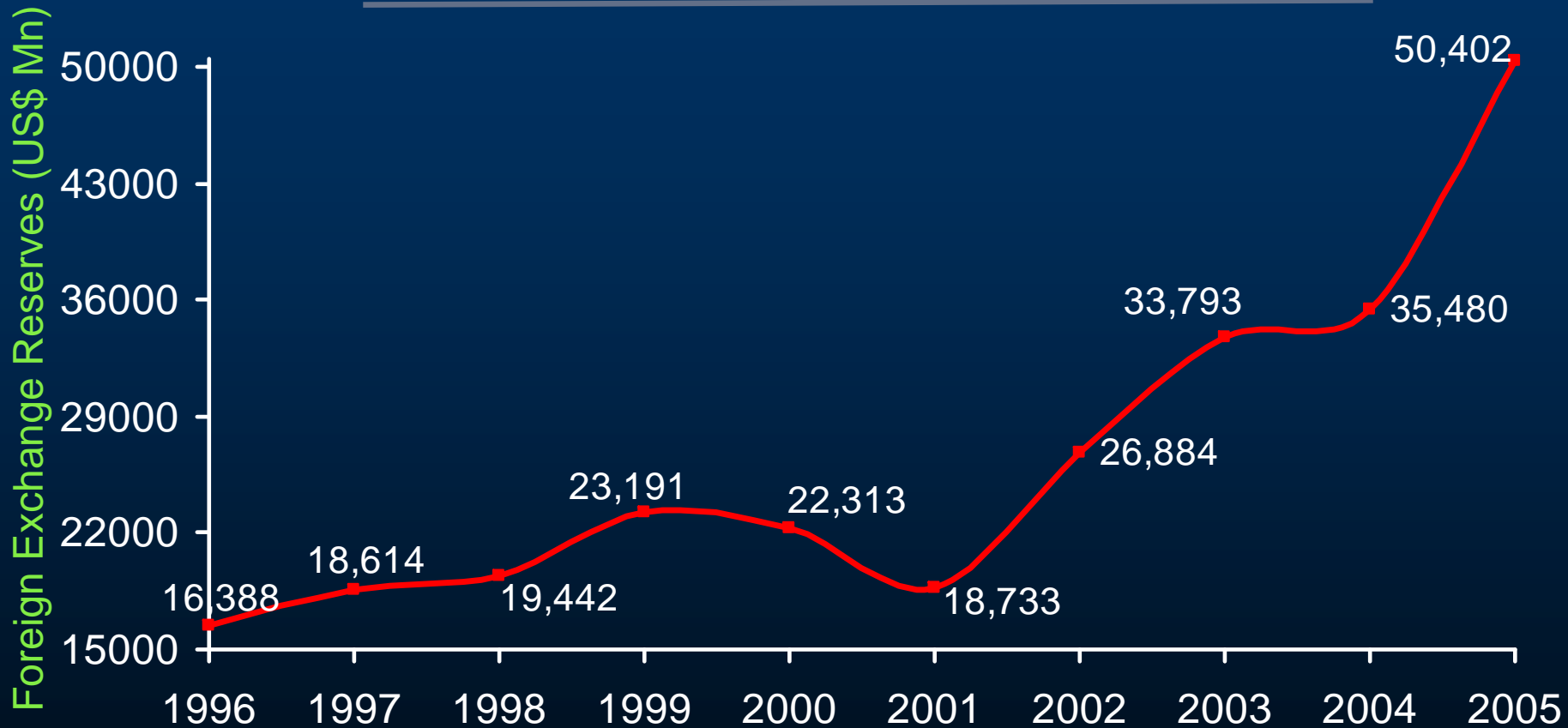

Boston Analytics Research

1. International Monetary Fund (<http://www.imfstatistics.org>)

More than thirty five percent of total population in Turkey is below 18 years

Percentage of Population below 18 Years vs. GDP per Capita (2005)¹

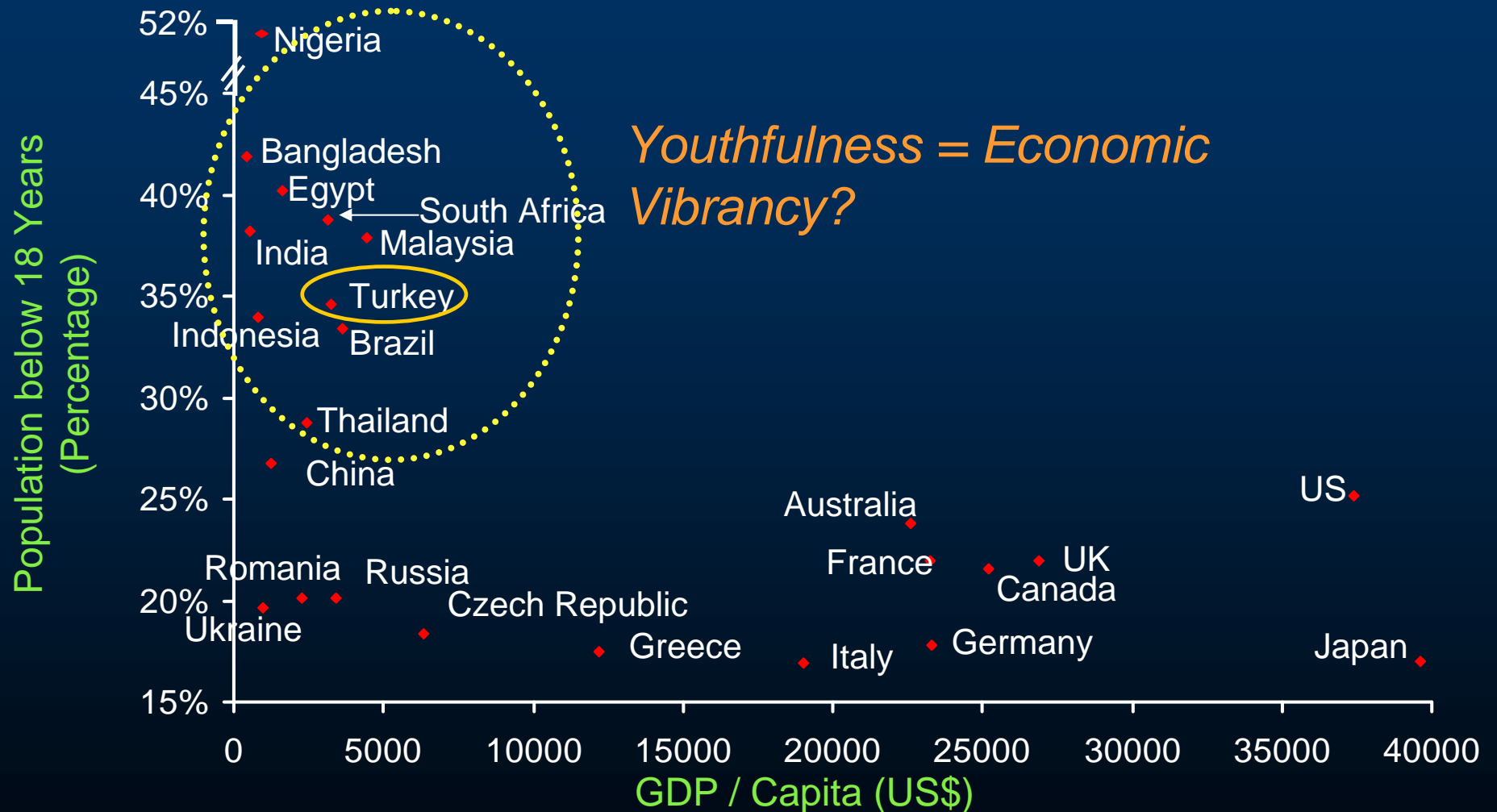

Boston Analytics Research

1. Energy Information Administration - EIA (<http://www.eia.doe.gov/>)

2. UN Nations Population Division (<http://www.un.org/ndf/fish/>)

However Turkey's trade balance has been declining

Trade Balance in US\$ Mn (1990-2005)¹

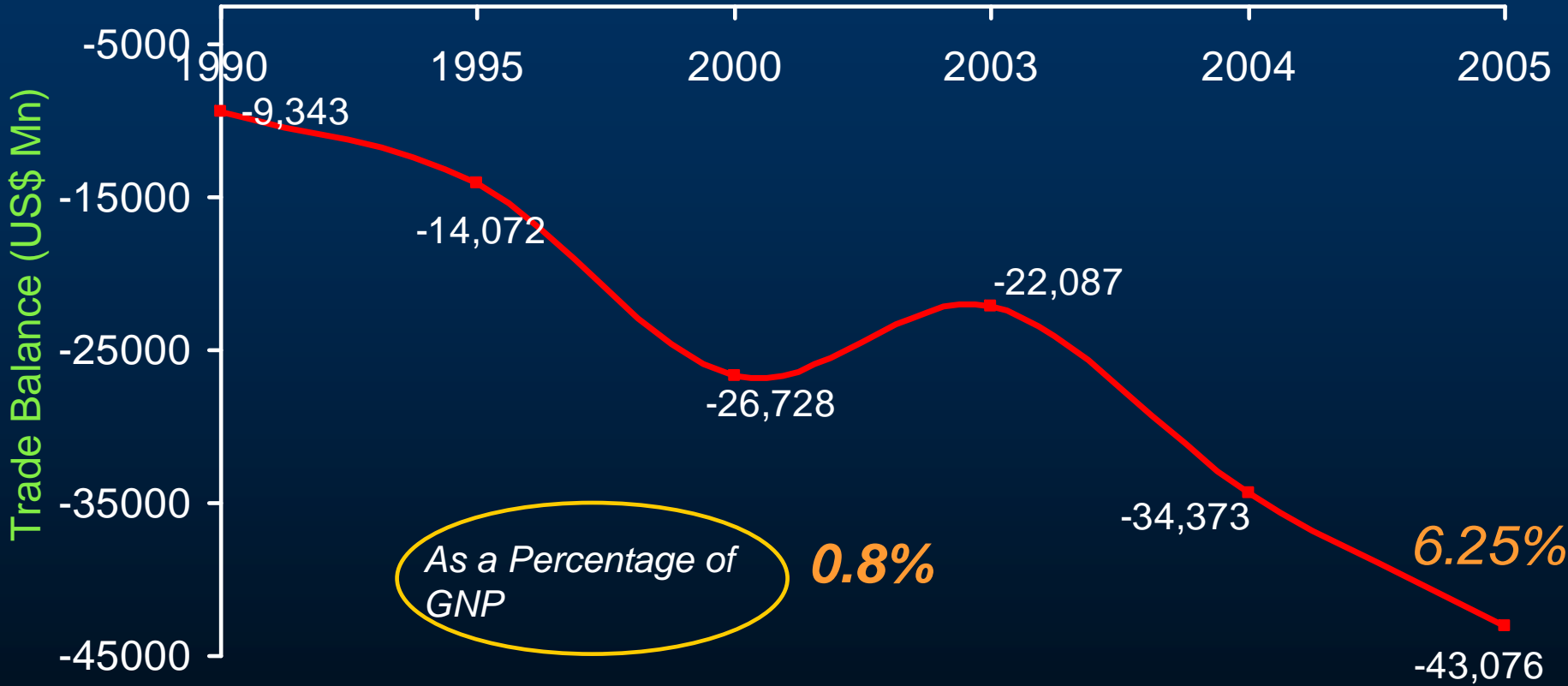

Boston Analytics Research

1. <http://www.byegm.gov.tr/REFERENCES/TURKEYS-FOREIGN-TRADE.htm>

Changing Global Environment and Turkey's Economic Possibilities imply *New Course ahead*

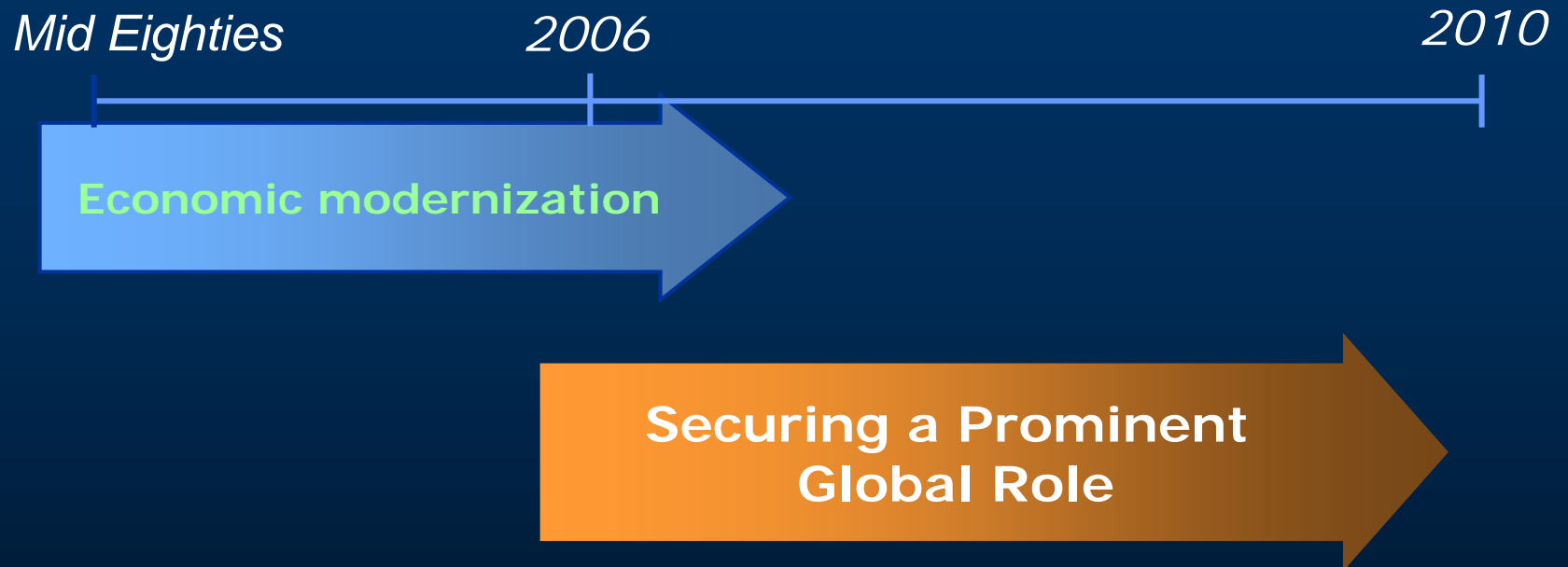

1. Improving the nation's long-term competitiveness (e.g. *Energy Strategy*)
2. Strengthening Turkey's Geo-Political role
3. Cultivating more confidence in the Corporate Sector

Accordingly, the new strategic game plan must ensure a new set of requirements are met

Internal Aspirations

- *Triggering a new era*
- *Increasing Global exposure*
- *Balancing socio-economic development process*

Global Environment

- *Power of new economics*
- *Short-lived technologies*
- *Rising environmental concerns*
- *WTO environment*

Significant values for excellence



High price of non-performance

Strategic Requirements

1. *Create distinctive competitive advantages*
2. *Select areas with winning possibilities*
3. *Evaluate possibilities with global perspective*
4. *Strategic guidance to drive leadership mechanisms*
5. *Emphasis on soft factors*

Three Essential Points:

1. The Current World Disorder: *The Potential Role Turkey Could Play ?*
2. **Securing Superior Economic Stature: Toward Enhanced Global Influence?**
3. Stimulating Innovation & Globalization through *targeted Growth Platforms ?*

Turkey's Position

- ❑ Strategic Location = *Gateway role* between East & West, North & South, between different streams of Enquiry
- ❑ Cultural Integrator
- ❑ Developing a socio-economic infrastructure (to *play the Value added Clearing house role?*)

Turkish economy must now aspire for a decade of growth similar to what Asian Nations have enjoyed

Average Growth Rate (1995-2005) vs. GDP* per Capita (2005)^{1,2}



Note : *Real GDP with base year 2000

Boston Analytics Research

1. Energy Information Administration - EIA (<http://www.eia.doe.gov/>)

2. UN Nations Population Division (<http://www.un.org/english/>)

Copyright © 2006 Partha S. Ghosh & Boston Analytics. All rights reserved.

China's manufacturing exports as a percentage of World manufacturing exports has increased by 4.5 times

Manufacturing Exports of Select Developing Countries as a Percentage of World Manufacturing Exports(1990-2004)¹

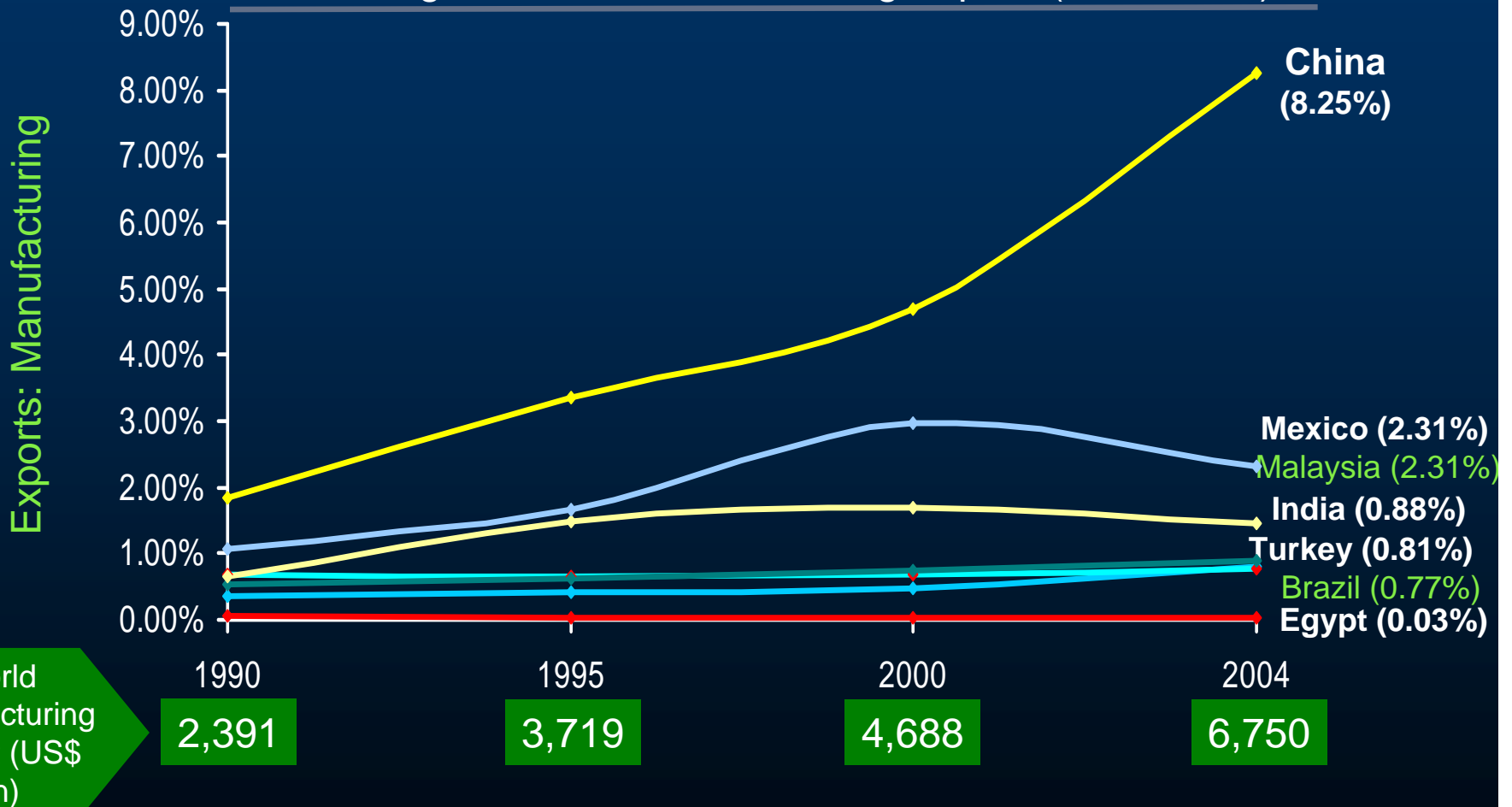

Boston Analytics Research

1. <http://stat.wto.org/Home/WSDBHome.aspx>

Turkey exports per capita could significantly increase

Exports per Capita of different Countries in US\$ per Capita (2005)^{1,2}

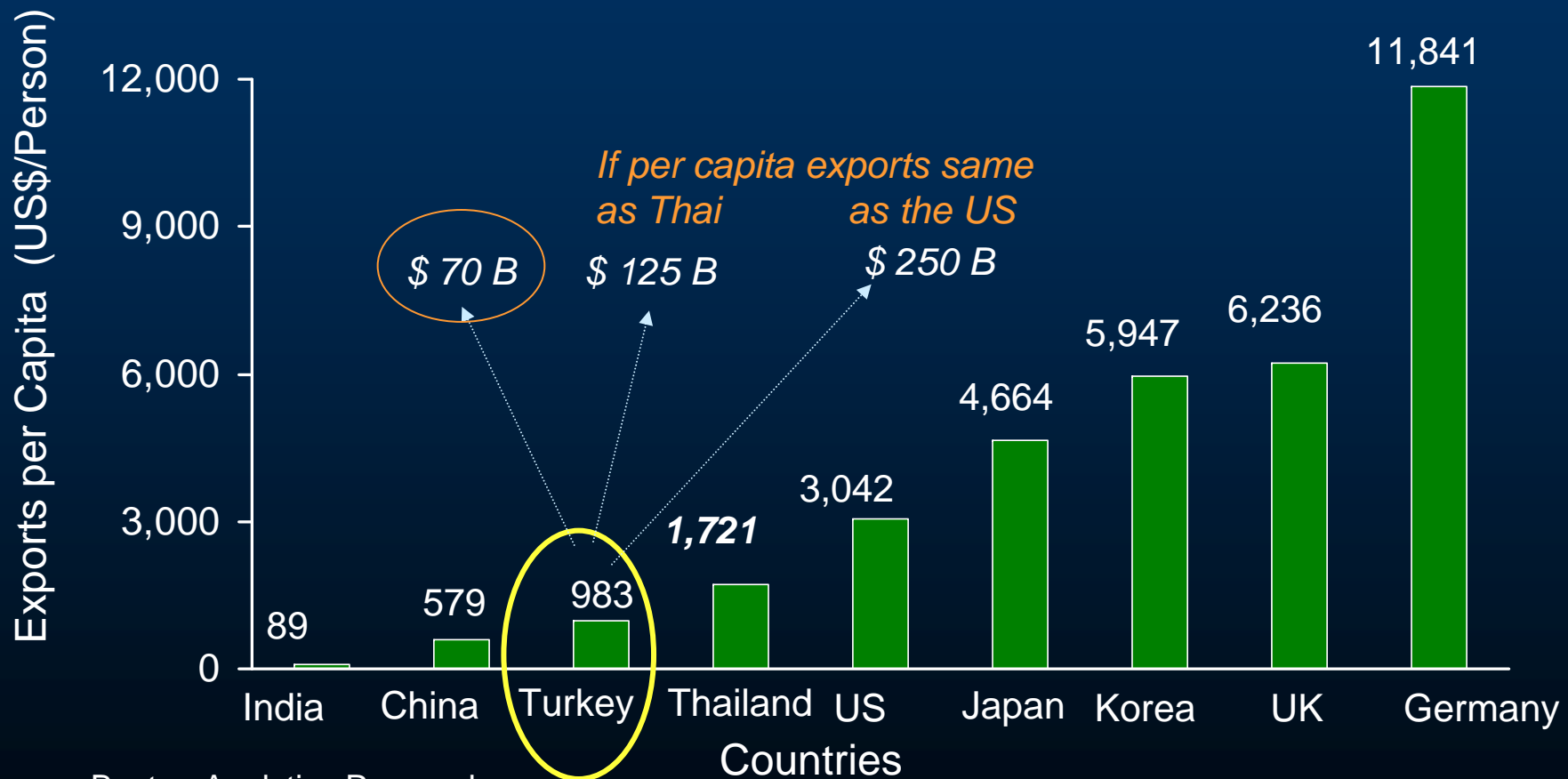

Boston Analytics Research

1. International Financial Statistics Online

2. <http://www.oanda.com/convert/fxhistory>

Turkey's trade deficit per capita could be a drag for its Economic Development

Average Growth Rate (1995-2005) vs. Trade Balance per Capita (2005)^{1,2,3}

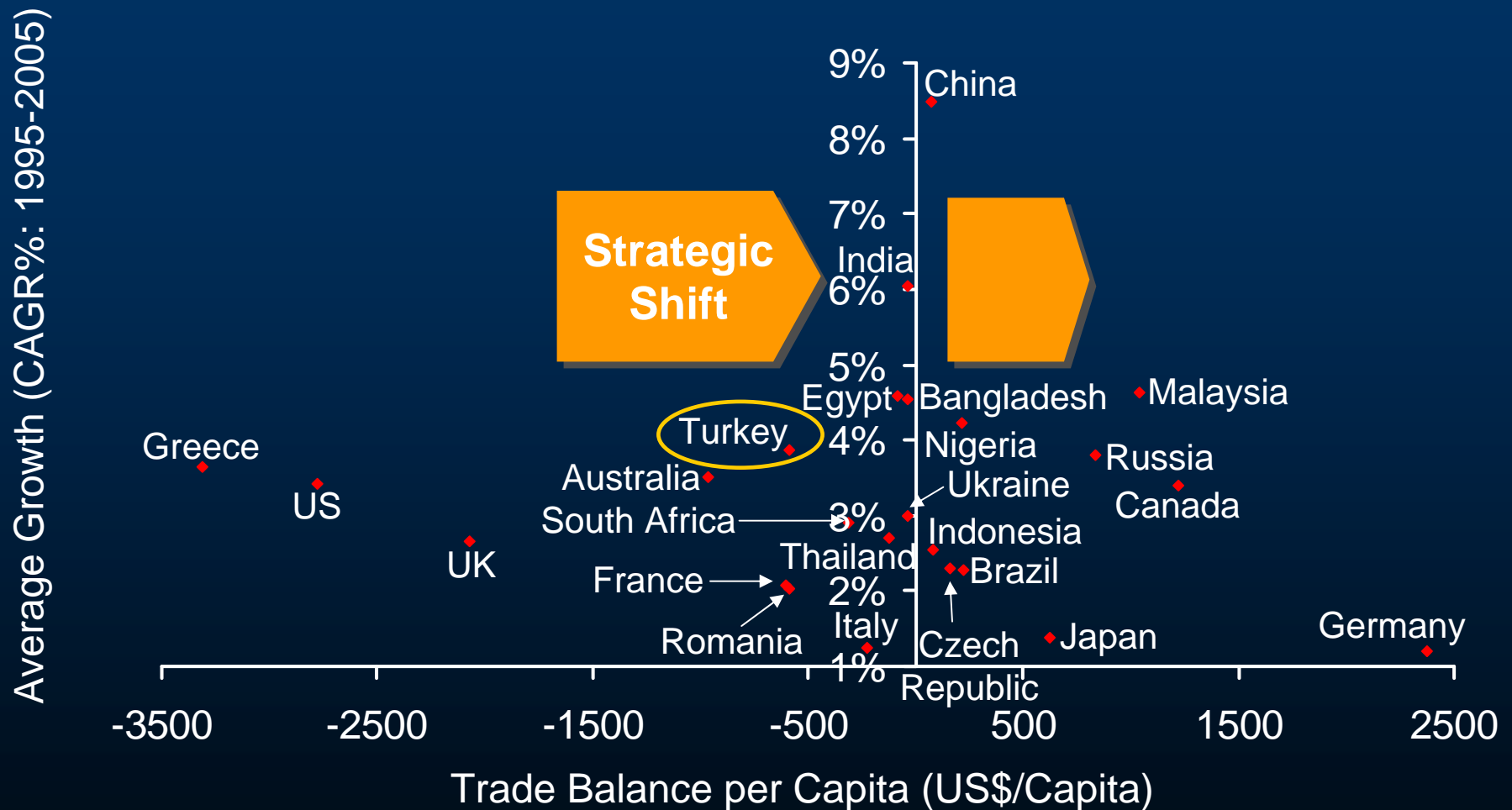

Boston Analytics Research

1. Energy Information Administration - EIA (<http://www.eia.doe.gov/>)

2. UN Nations Population Division (<http://www.un.org/english/>)

3. World Trade Organization (<http://stat.wto.org/>)

Moving forward Turkey must evolve Global Strategy similar to South Korea in late 70s & Japan in early 70s

GDP per Capita in US\$/Capita: South Korea , Japan and Turkey (1971-2005)

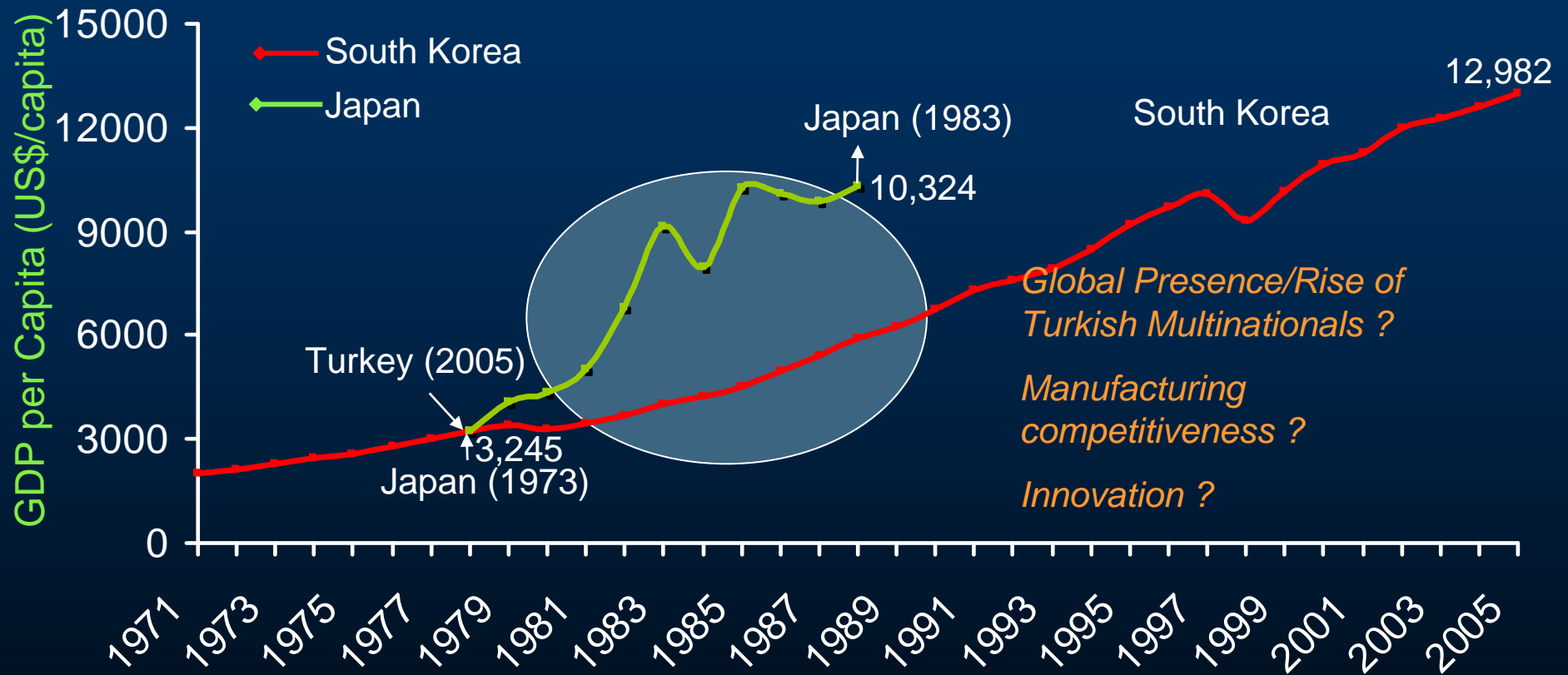

Boston Analytics Research

1. International Monetary Fund (<http://www.imfstatistics.org>)
2. <http://www.oanda.com/convert/fxhistory>
3. World bank data ???

Strategic Framework for defining the economic value propositions

The basic framework: Strategic Triangle for Regional Strategies

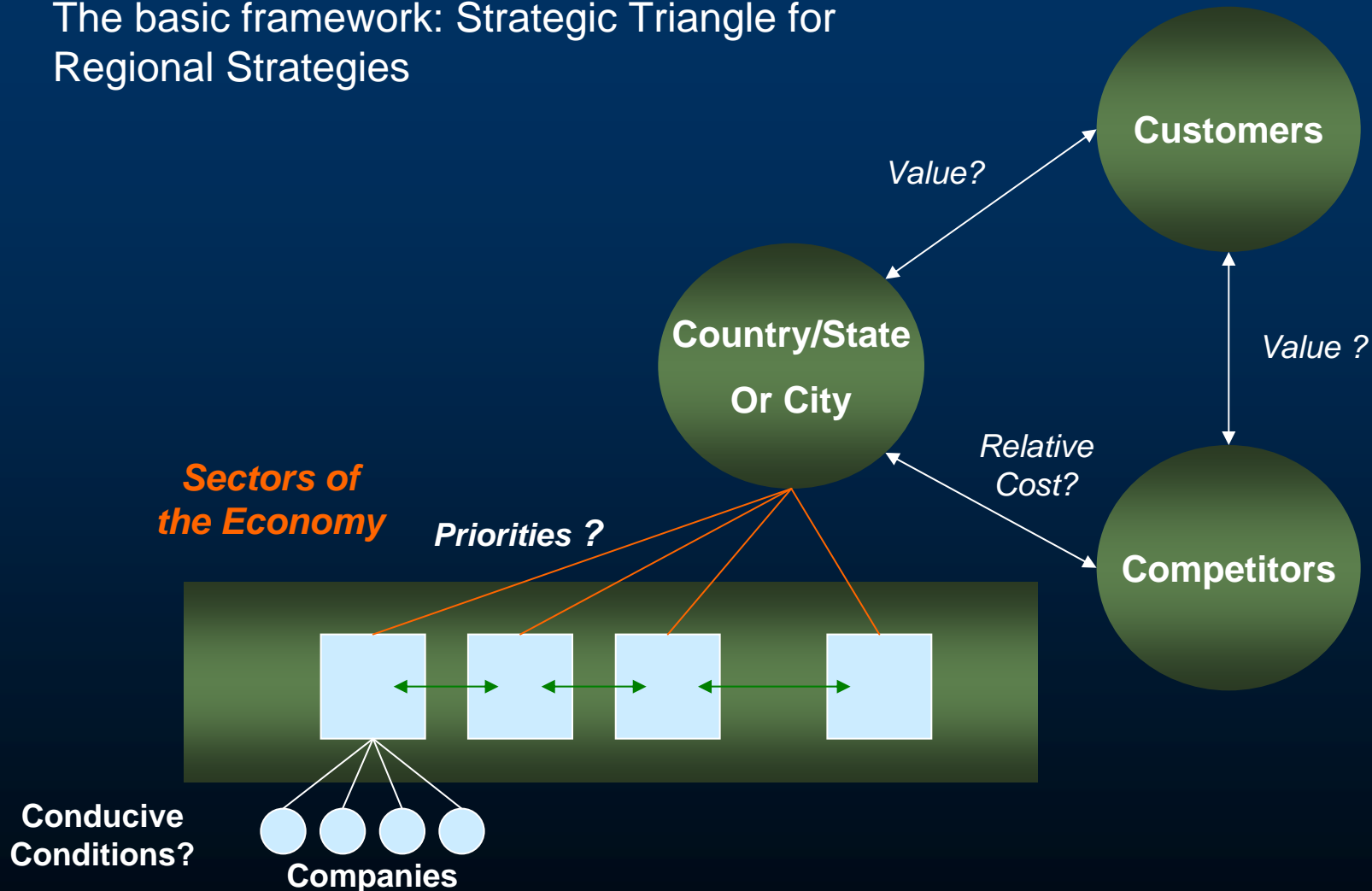

A Strategic framework that group industries into different roles requiring different policy and infrastructure supports

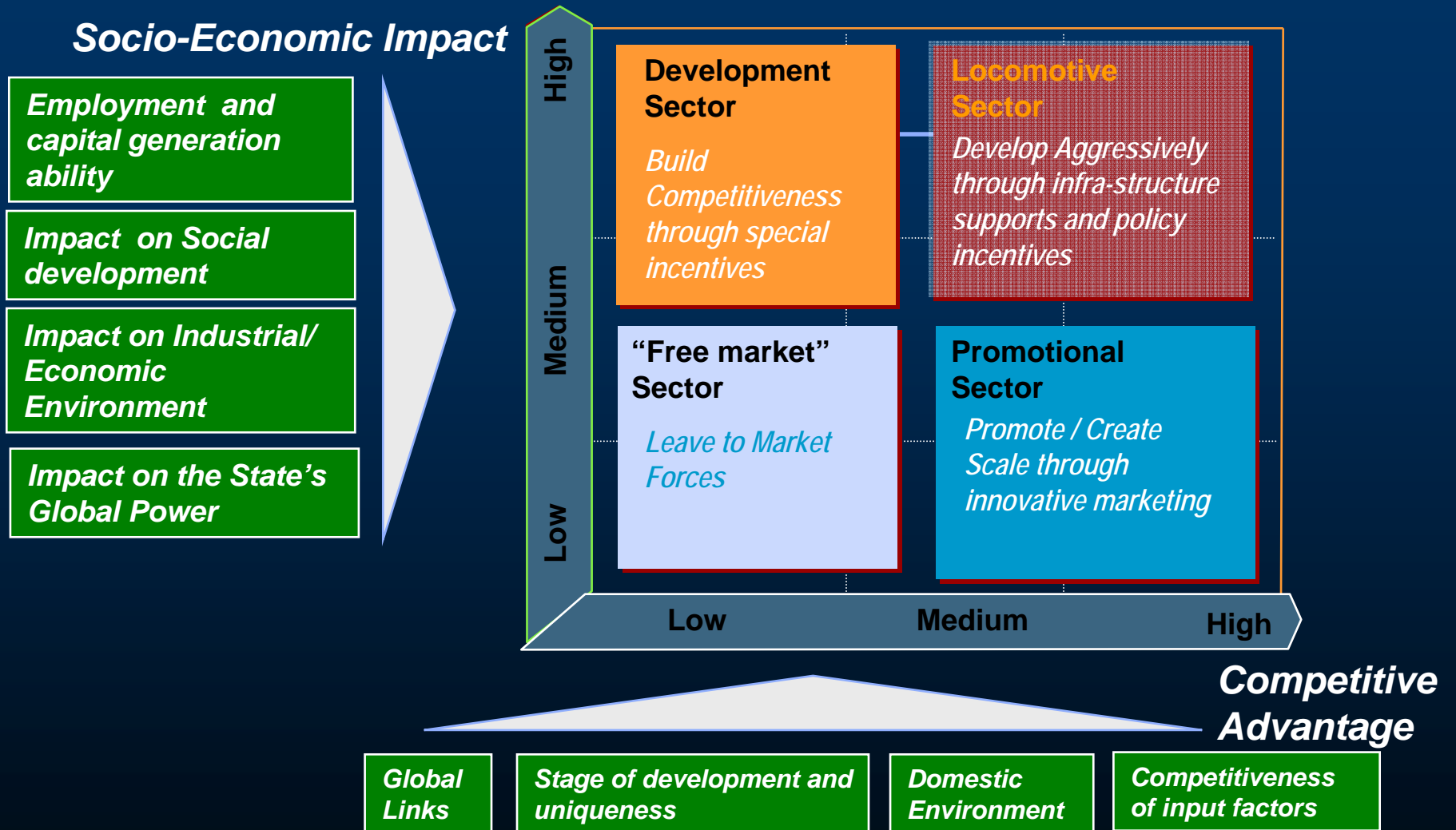

Several Industries in Turkey could emerge as the locomotive of economic growth

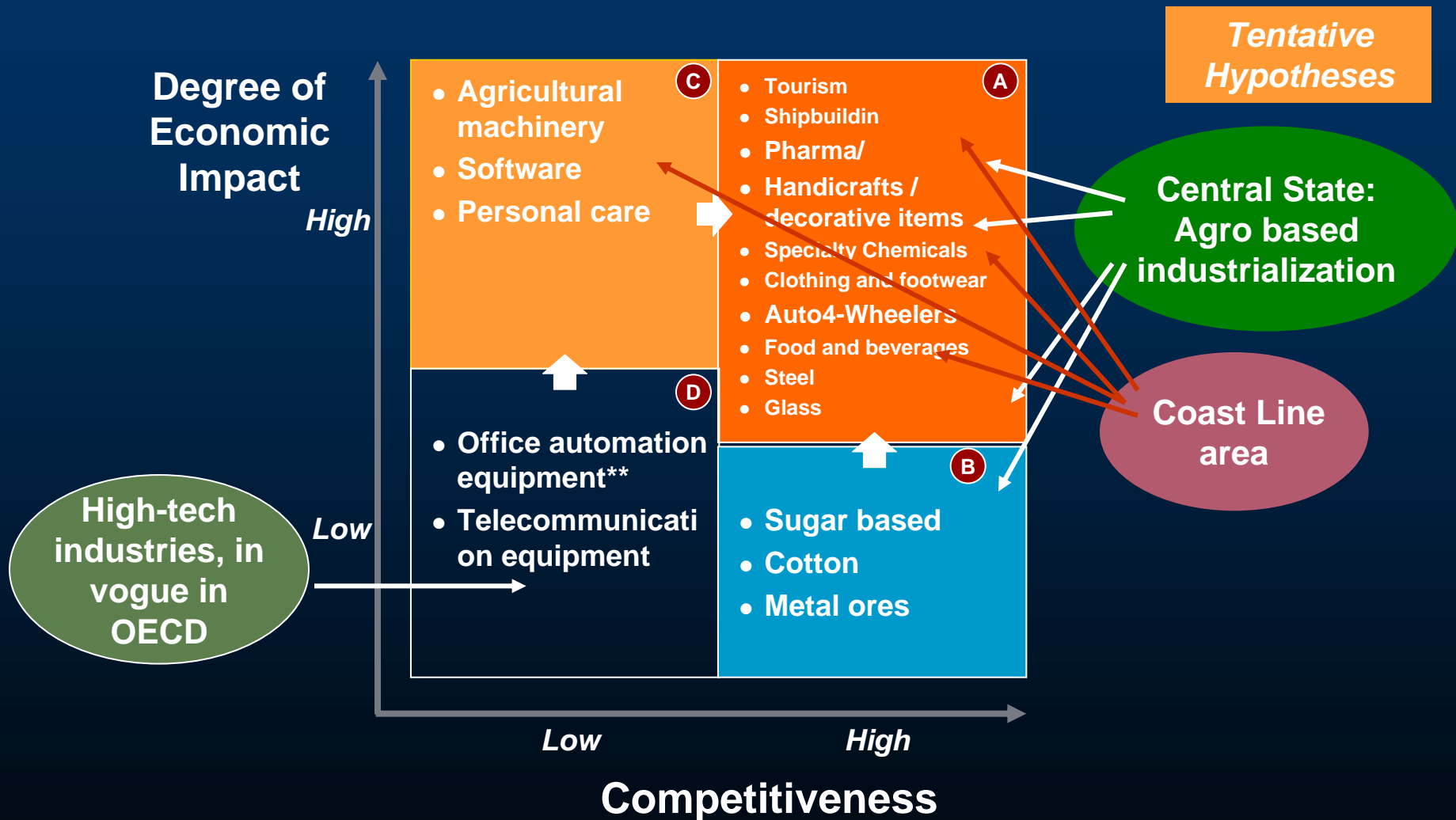

* As finished product
 ** Until volume picks up

Priority industries must drive infrastructure/utilities strategy and promoted through market mechanisms

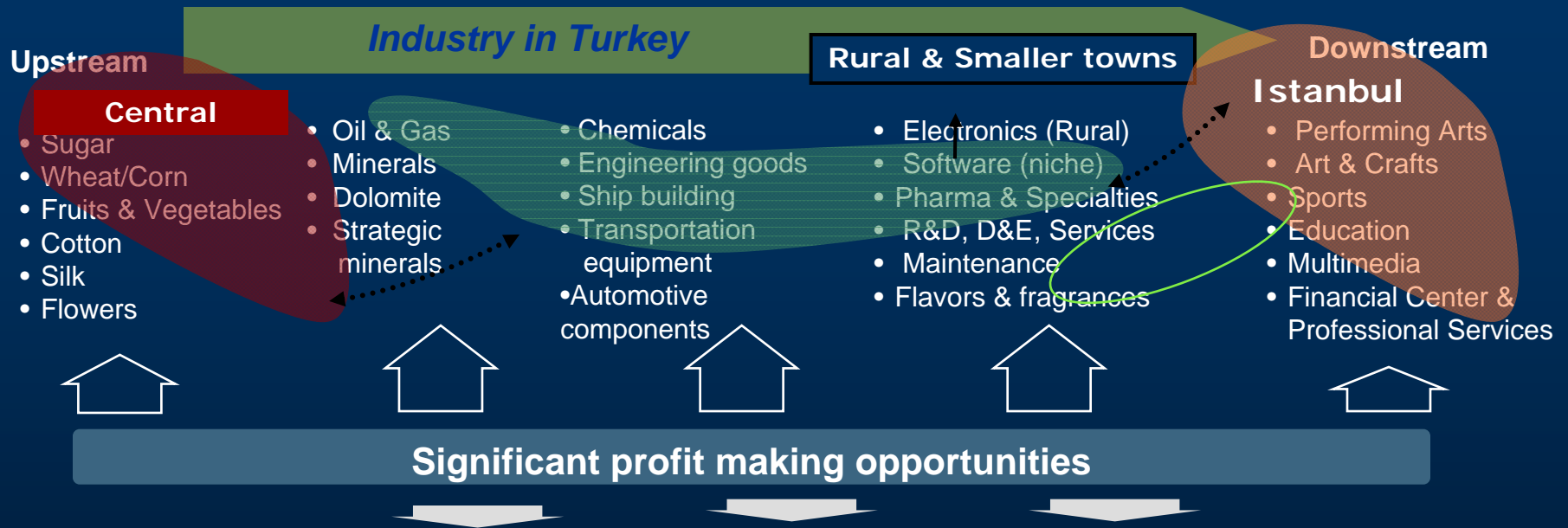

World scale projects through innovative market mechanisms

- Energy & Power Strategy
- Airports and Airstrips
- Roadways & Railways modernization
- Dockyards to match Shanghai, Yokohama and Korean Ports
- Waterways development
- Water management
- Sanitation & Recycling Strategy

Holistic Approach?

PROBLEMS ≈ OPPORTUNITIES

Holistic Approach

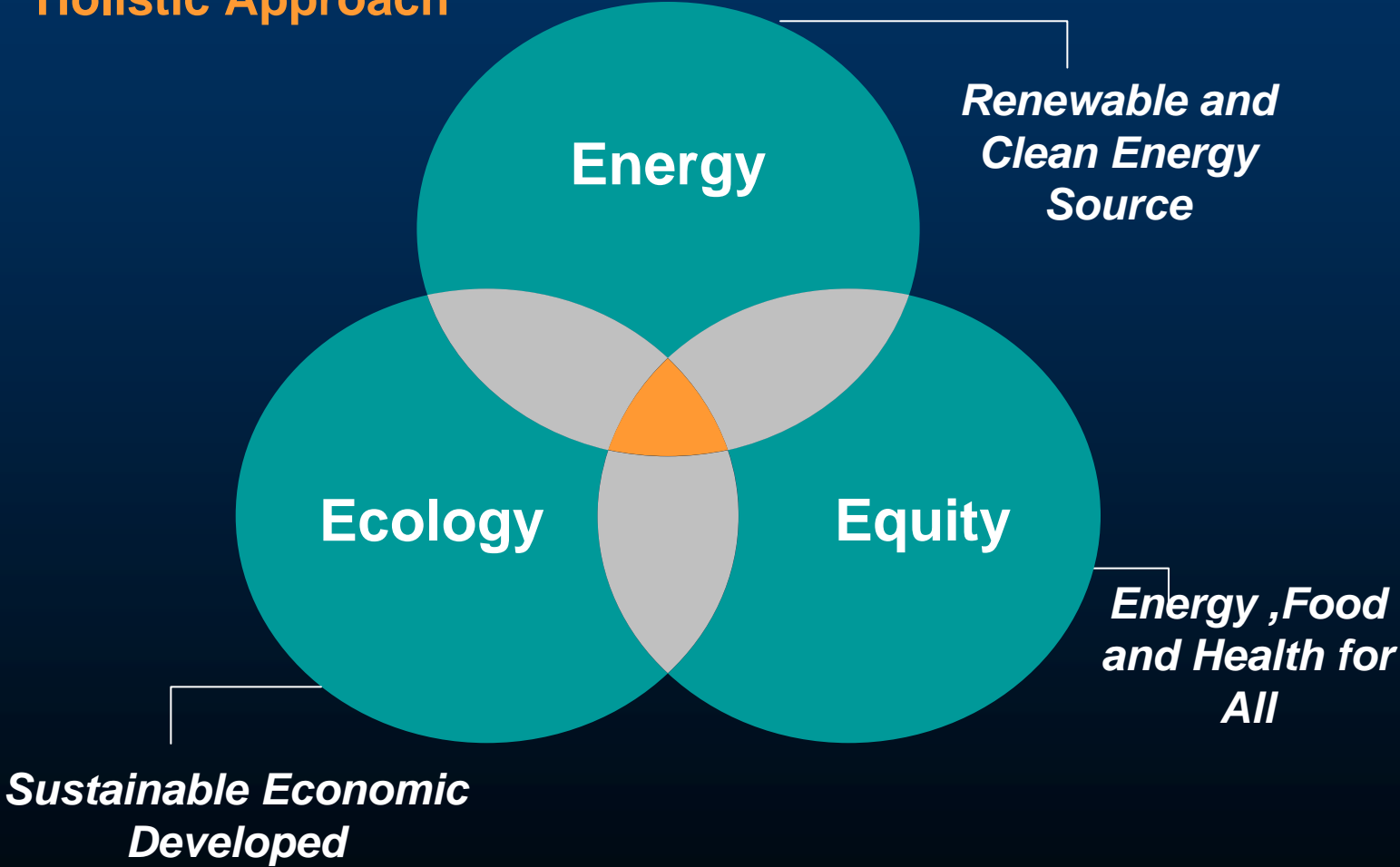

Turkey's Energy Strategy will be central toward creation of a Vibrant Economy

Energy Consumption per Capita vs. GDP per Capita (2004)¹

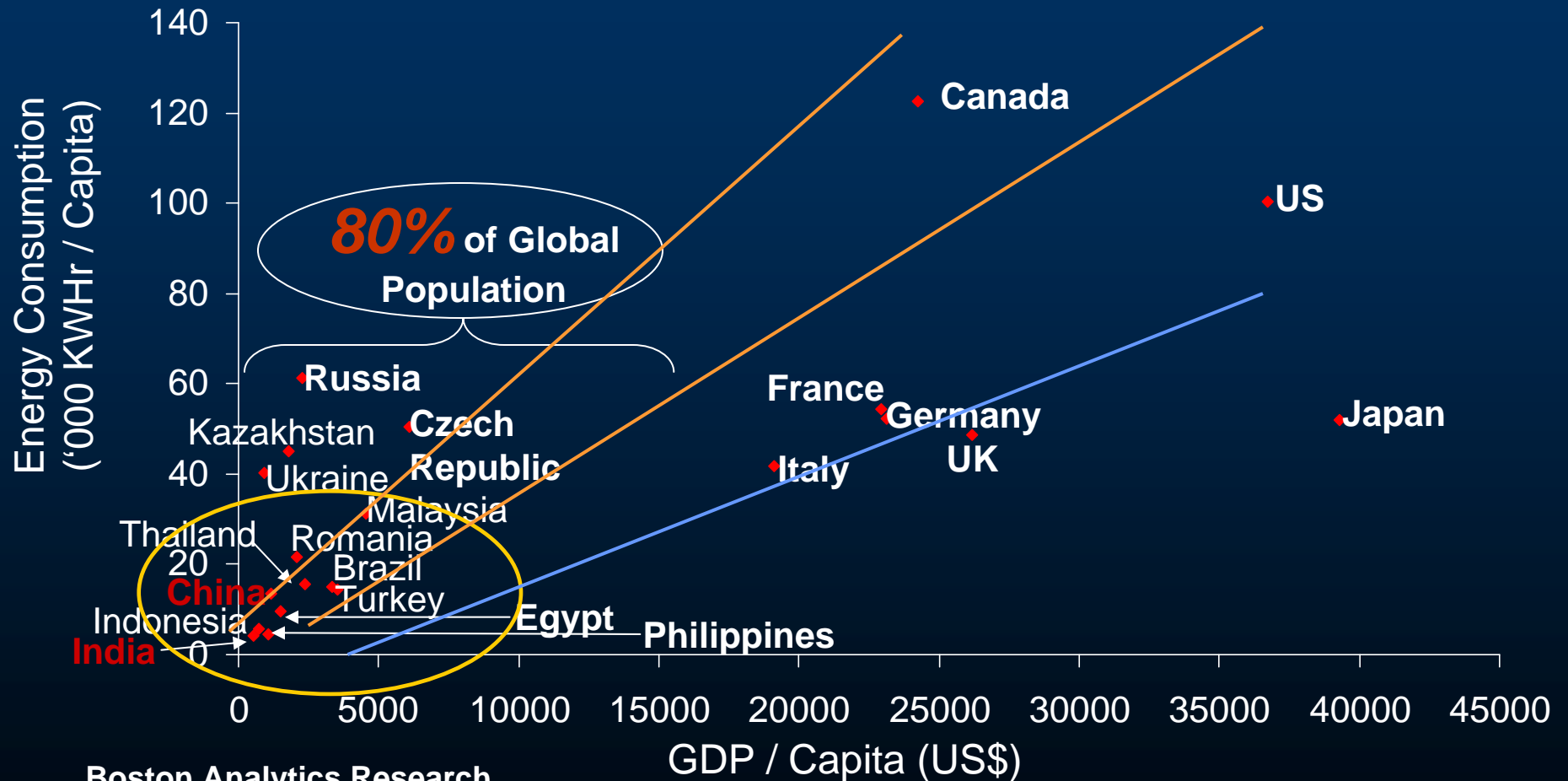

Boston Analytics Research

1. Energy Information Administration - EIA (<http://www.eia.doe.gov/>)

Large Scale Engineering Systems approach must drive Turkey's Vision of NextGen Distributed Power Infrastructure

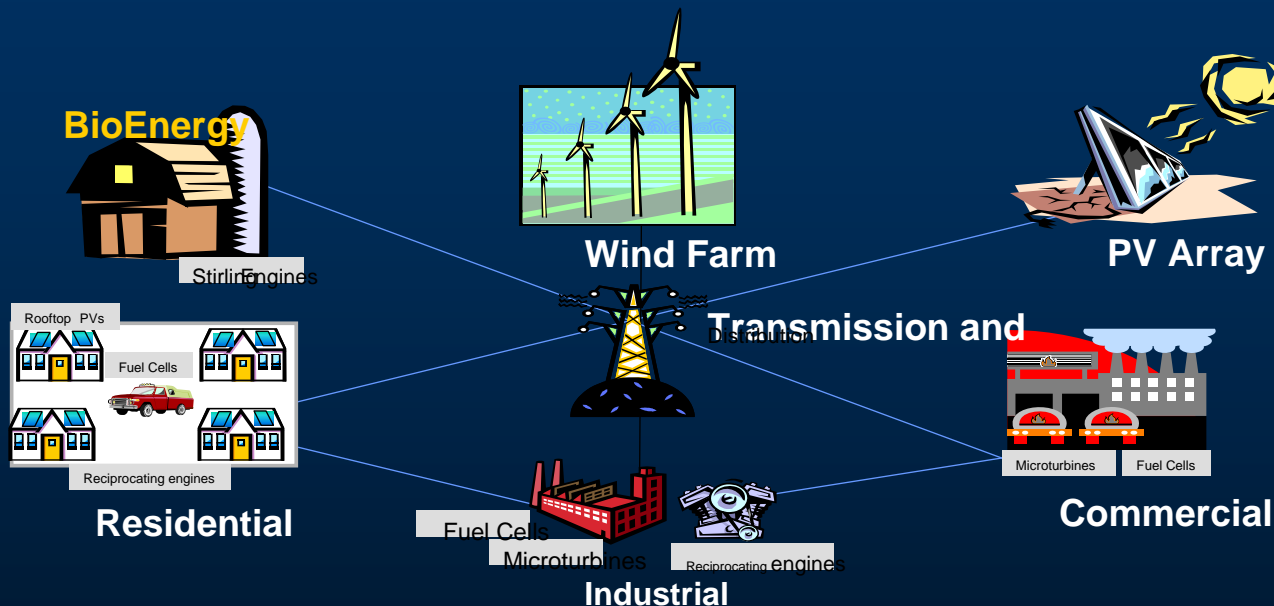

The Virtual Power Plant

- *Aggregates the output of thousands of micropower technologies*
- *Peak shaving becomes power trading on the wholesale market*
- *Coordination and control through a new communications infrastructure*

Not Either/Or Unification

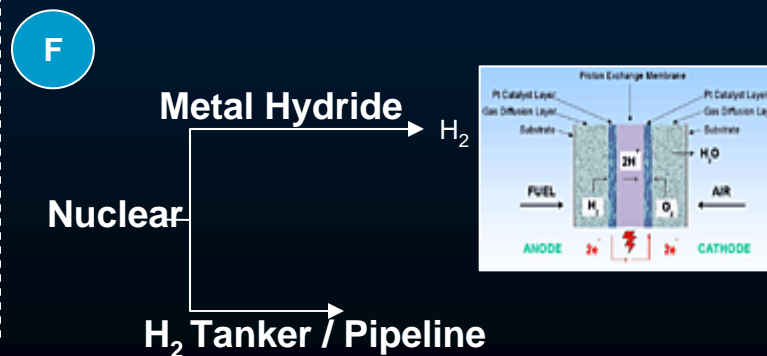
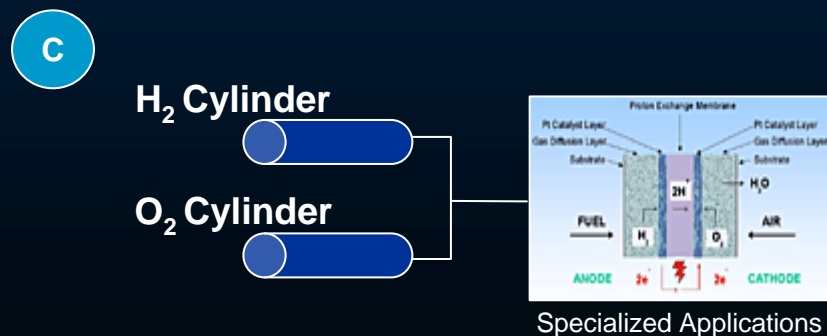
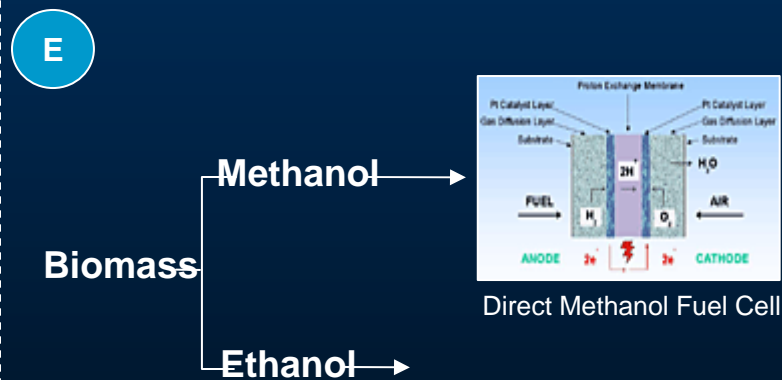
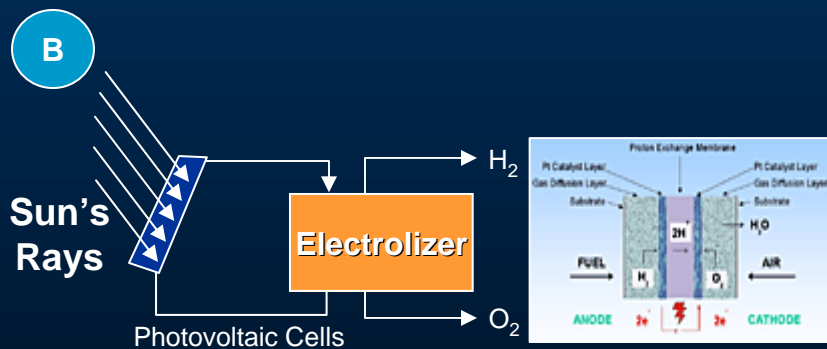
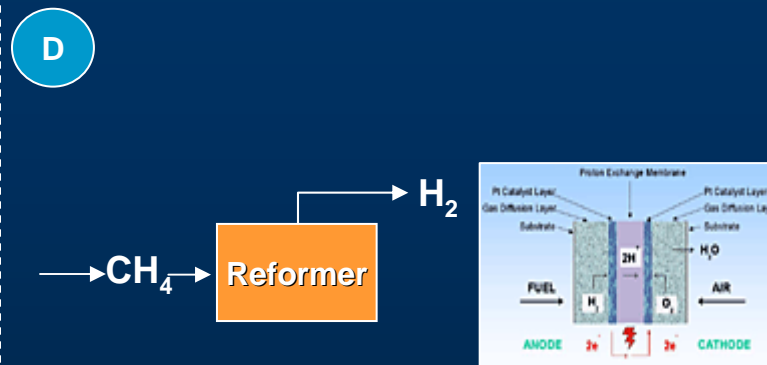
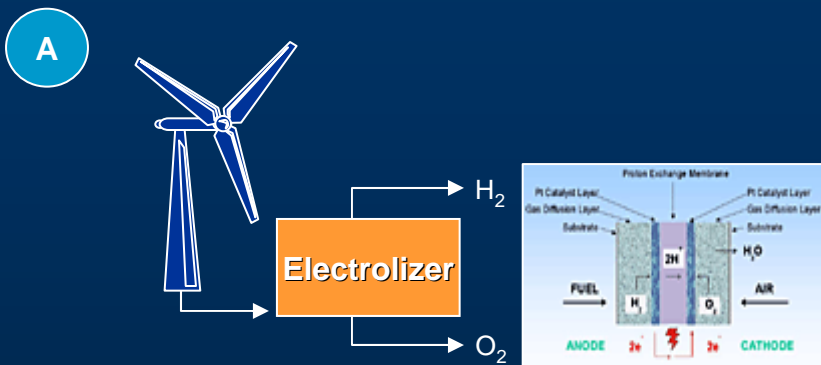

Engineering Systems Advanced Solid Modeling Capability

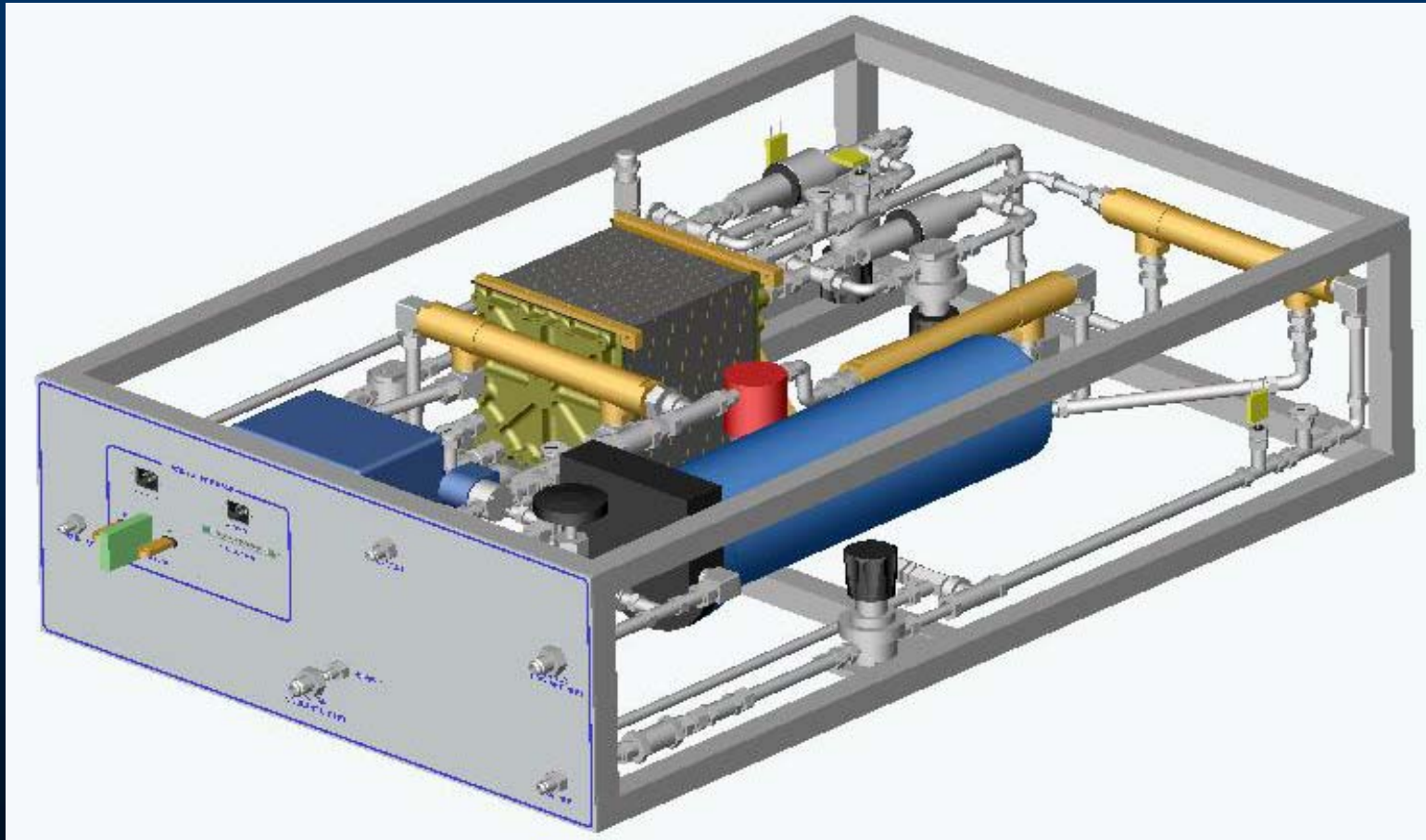

Engineering Tools Include Autocad, Solidworks, Thermal Analysis System, Fortran, C++

Three Essential Points:

- 1. The Current World Disorder: *The Potential Role Turkey Could Play ?***
- 2. Securing Superior Economic Stature: *Toward Enhanced Global Influence?***
- 3. Stimulating Innovation & Globalization through *targeted Growth Platforms ?***

Turkey's New Role?

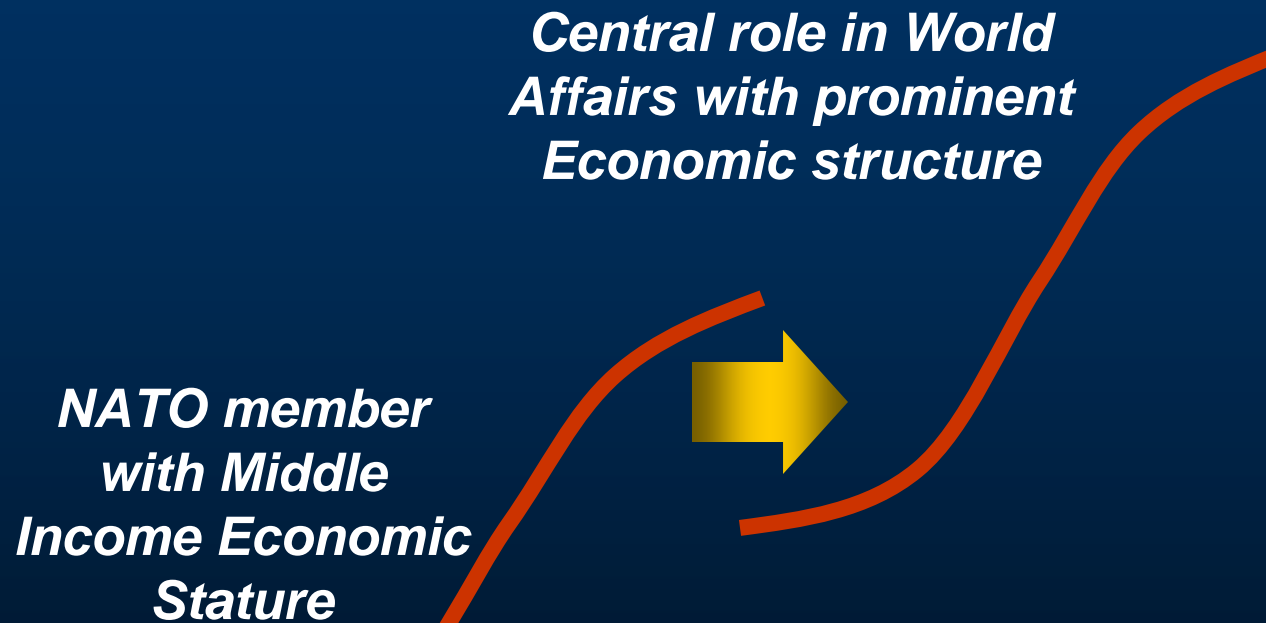

Accordingly the New Paradigm must Embrace both *Outside-in Thinking* & *Inside out Initiatives*?



Graduation of manufacturing will require development of “Hubs of Excellence” of Knowledge & Services

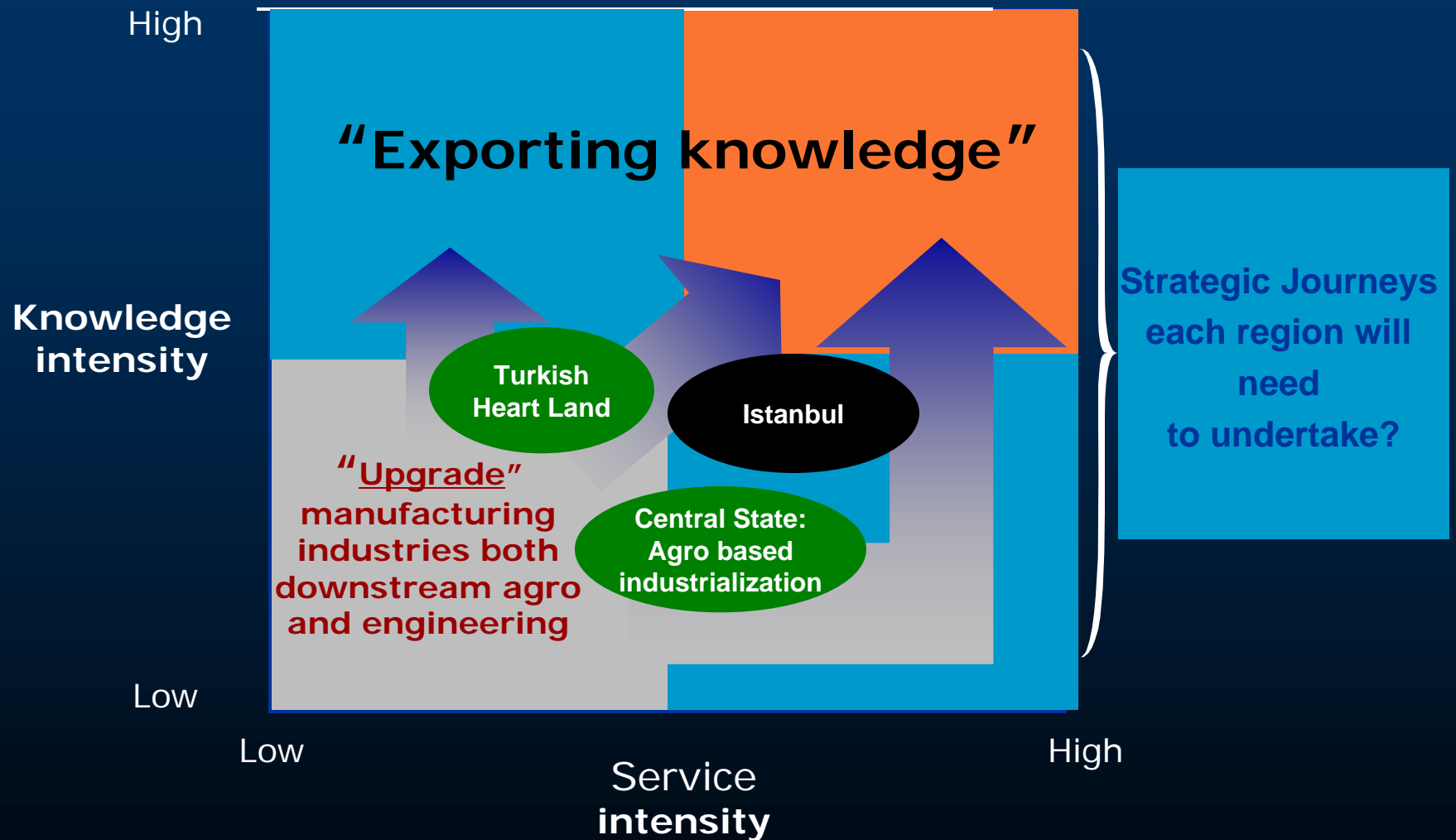

Turkey has to fundamentally has to significantly improve its Innovation Capacity

Total No. of Patents Issued by USPTO to Turkey (1996-2005)¹

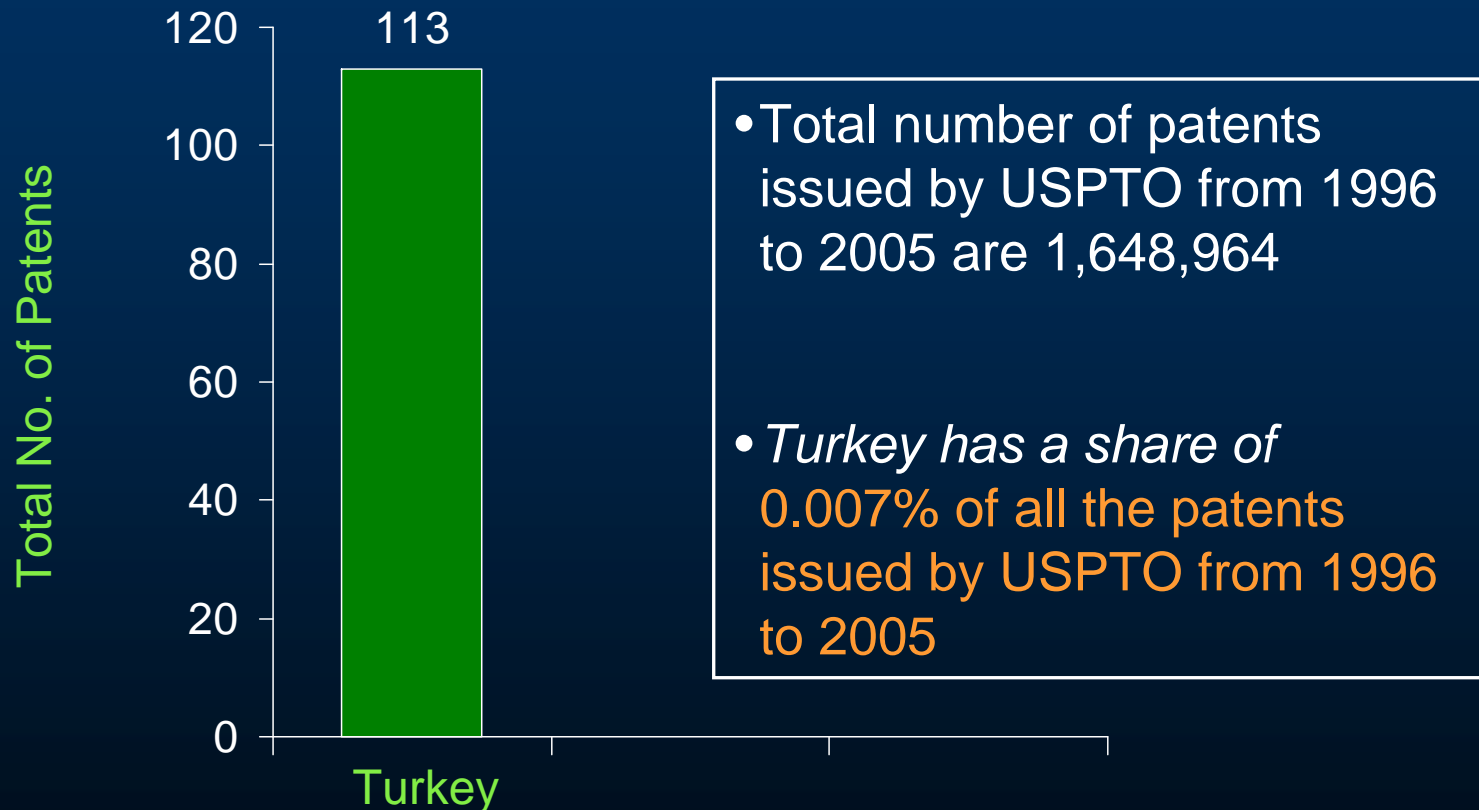

Boston Analytics Research

1. "Patents counts by country/state and year, January 1, 1977 – December 31, 2005", USPTO

Turkey's future competitiveness in knowledge intensive services is essential

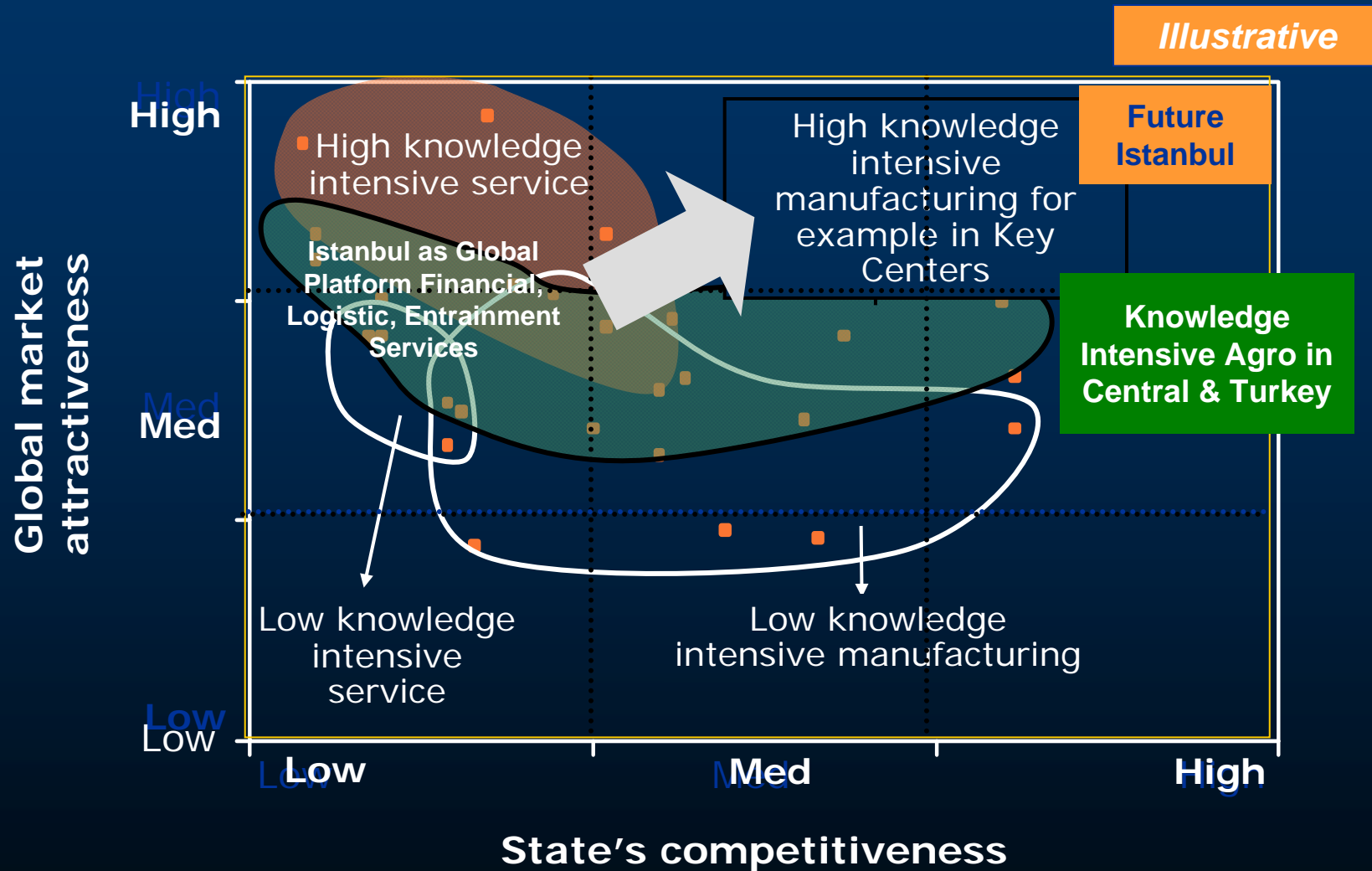

Different regions of Turkey must be strategically developed as Growth Platforms

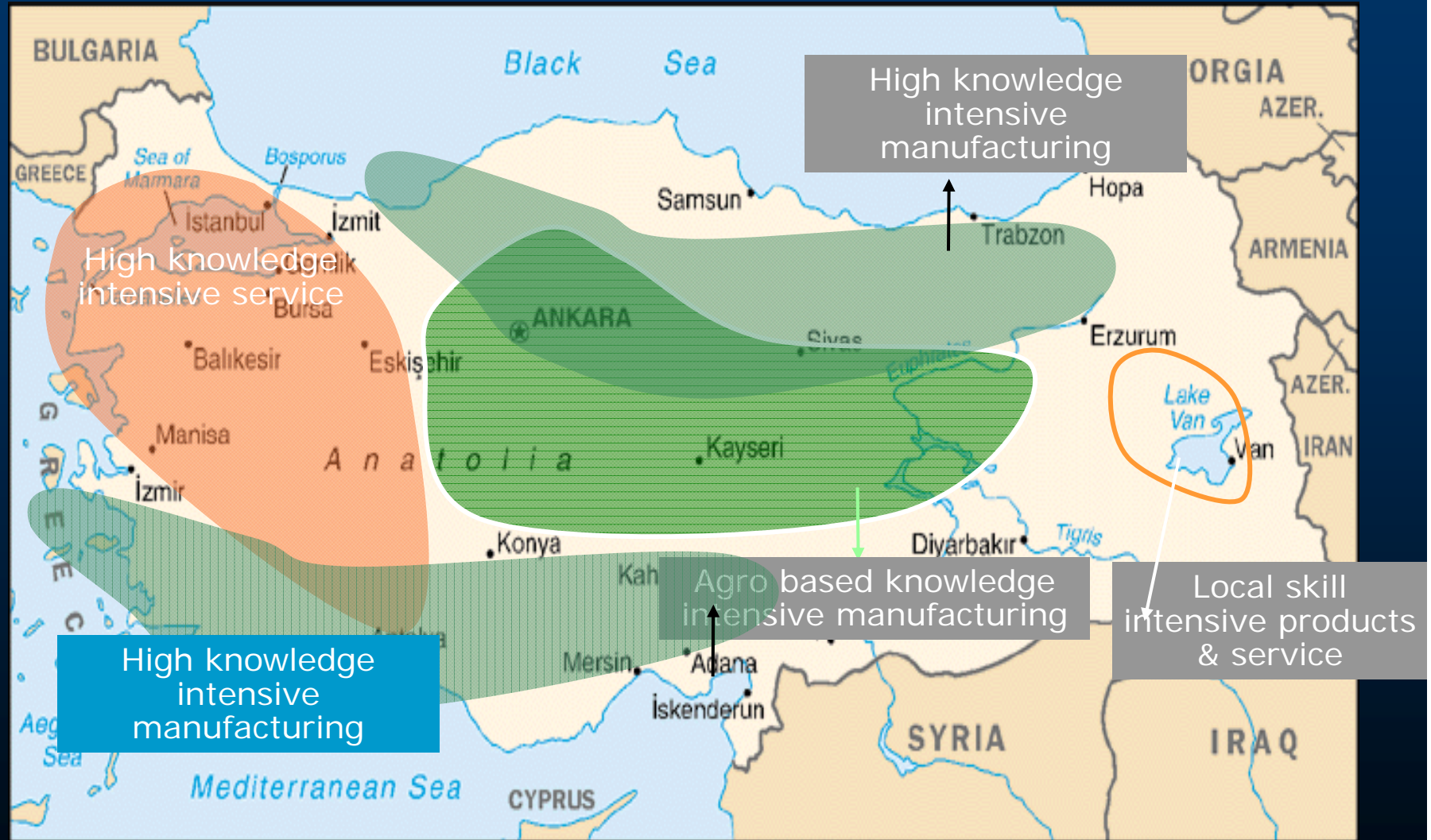

Turkey's Agenda

Bold Moves - Balancing Strategic with Opportunistic Plays

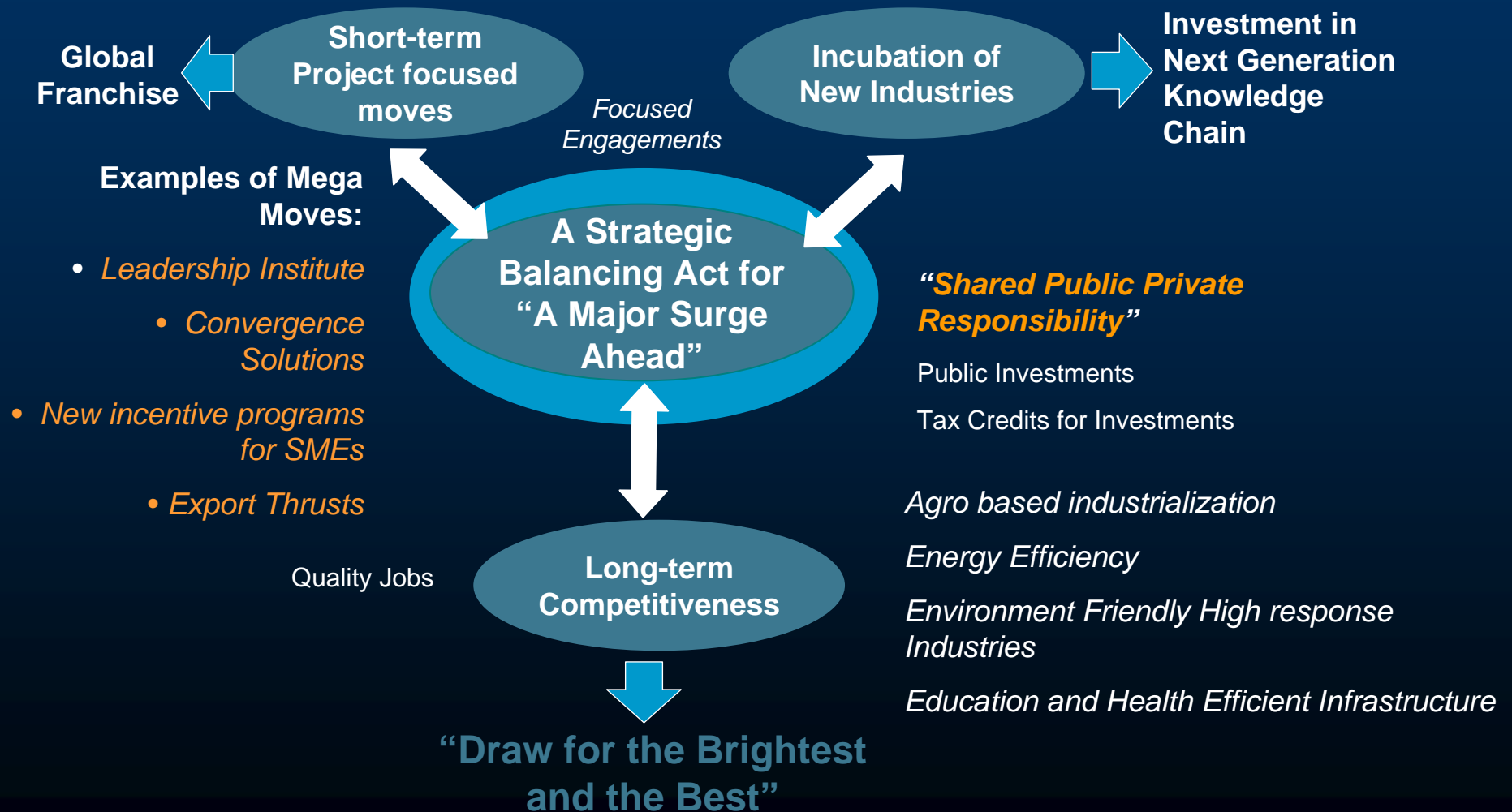

Examples of a Few Initiatives:

1. *Develop a Vision Paper from outside in view with the support of TÜSIAD*
2. Organize a Policy forum in Turkey
3. **Stimulate bottom up Entrepreneurship and to encourage volunteering**
4. Spark Innovation and increase Exports: *Innovation Turkey*
5. Promote a top notch Management / Leadership School *where US Schools end*