



The Frontiers of New Energy Paradigm: *Cultivating the Courage to Create The New Dynamics*

Partha S. Ghosh

*Global Energy Conference
Houston 2006*

Choices: Where will the Oil & Gas Profits go?

Total Net Profit in Billion US\$ of Fortune Global 50 Companies (2005)^{1,2}

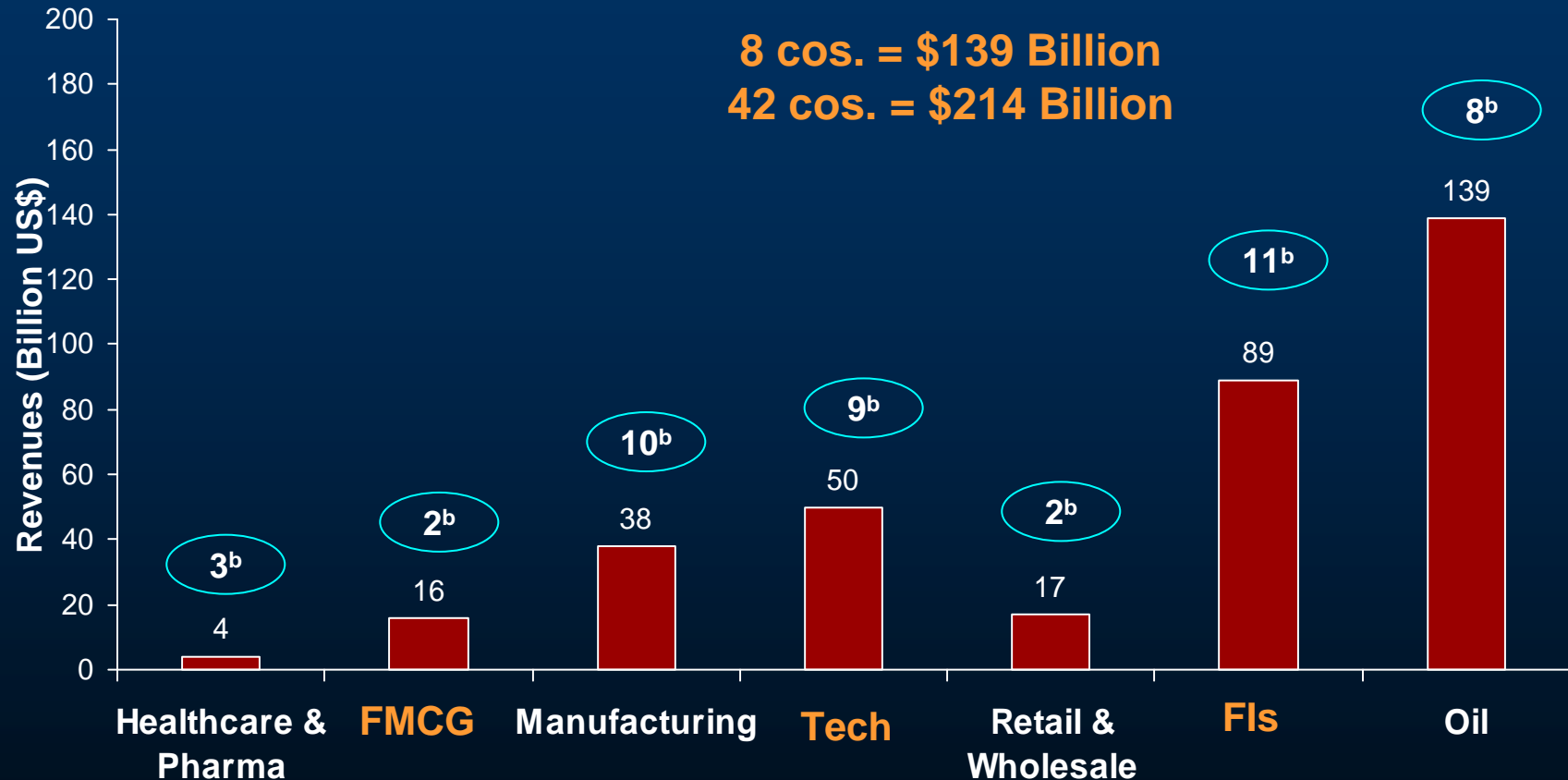

Boston Analytics Research

Courage: Reduction in energy intensity could reduce world energy demand by 14% in 2025

World Energy Demand in Quadrillion Btu (2025)¹ :If Energy Intensity is Reduced in Selected Regions

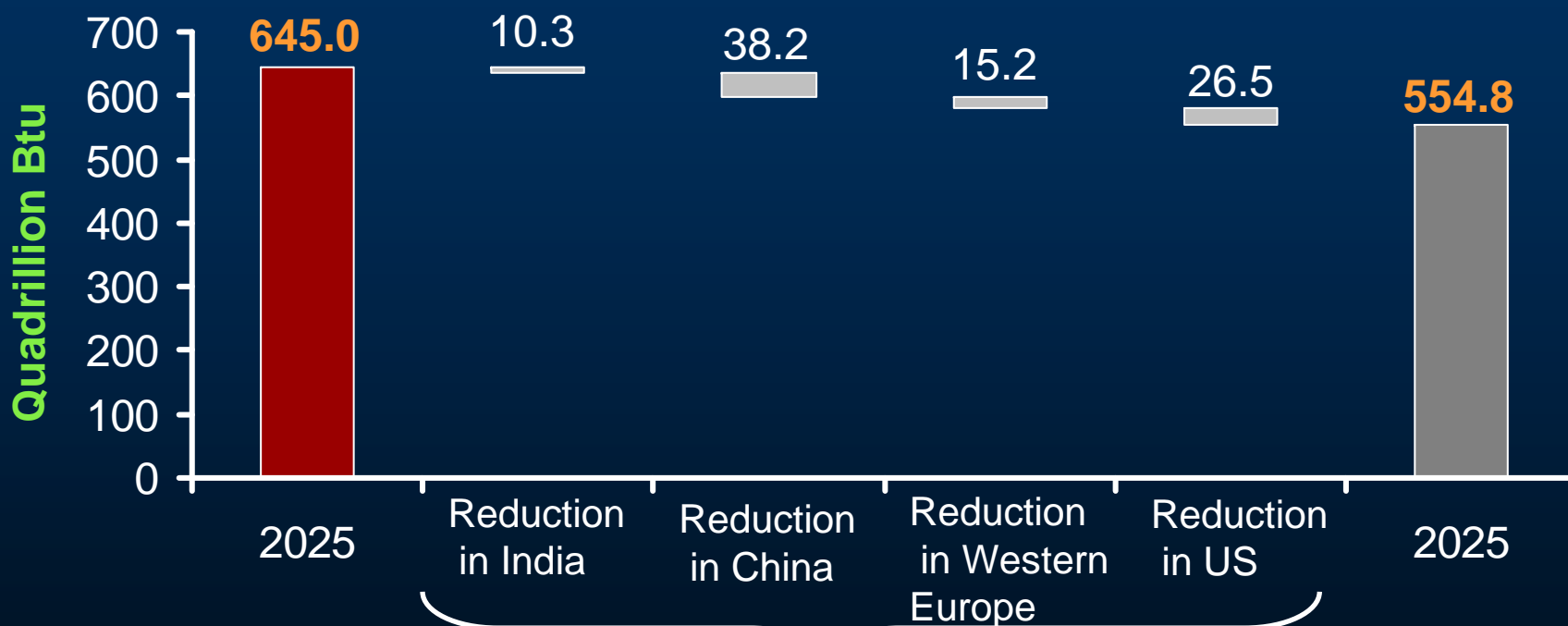

Assumptions:

- Energy intensity is reduced by 35% for India and China
- Energy intensity is reduced by 20% for Western Europe (WE) and US

Commitment: To Shape social behavior?

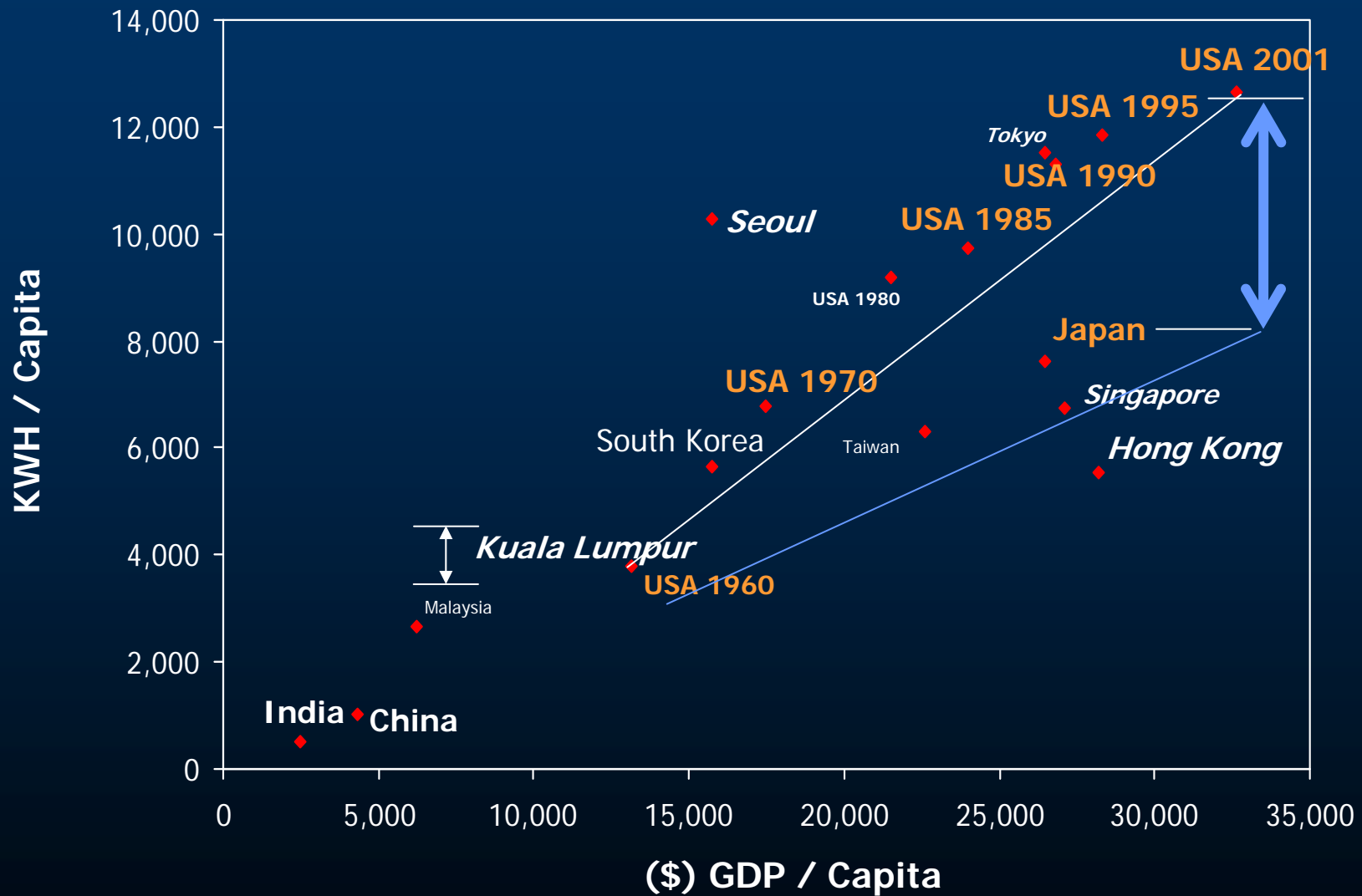

Contents

- *Laws of Large Numbers & Network Effect? Slow Pace of Large scale world wide Energy disruption?*
- *More & better of the Same or New Game? Market Mechanisms vs Cross Border Strategic Diplomacy?*
- *A Call for a Renaissance: Time to rethink, repurpose and reform?*

Note: Analyses supported by Boston Analytics

Since the Early Nineteen Hundreds

Early days of Electricity & Auto

2006



Era of Extraction & Automation

Overcoming barriers of socio-economic development

New Realization of space and time

Supply Infrastructure to fuel demand

Forecasting & Futility ?

Expected Natural Gas Wellhead Prices in U.S by 2025 (\$ per MSCF)

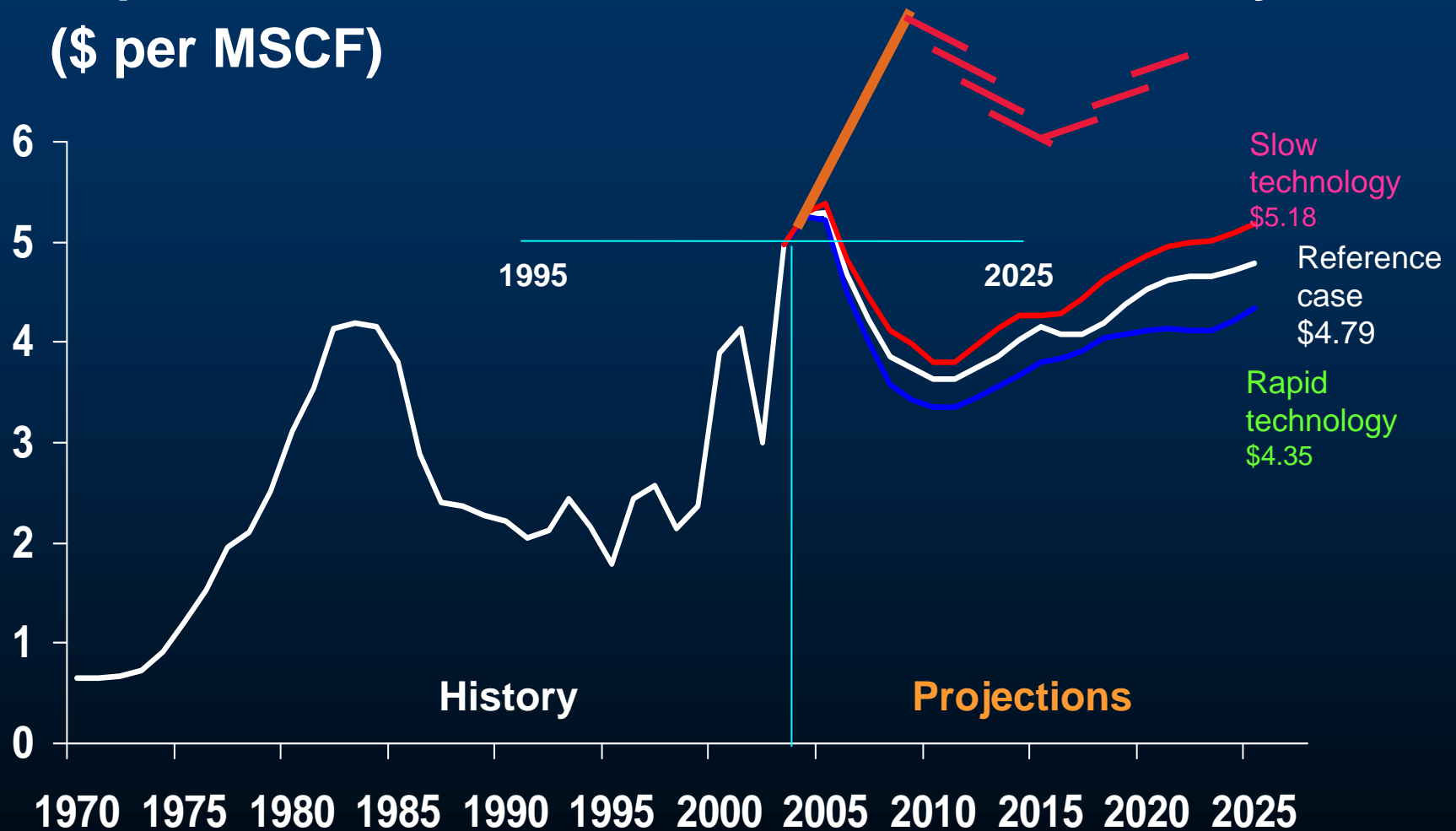

Source: Annual Energy Outlook 2005

Certainty of Global CO₂ emissions: Slow Pace of Dangerous Change

World Carbon Dioxide Emission in Million Metric Tons
(1980 to 2050*)¹

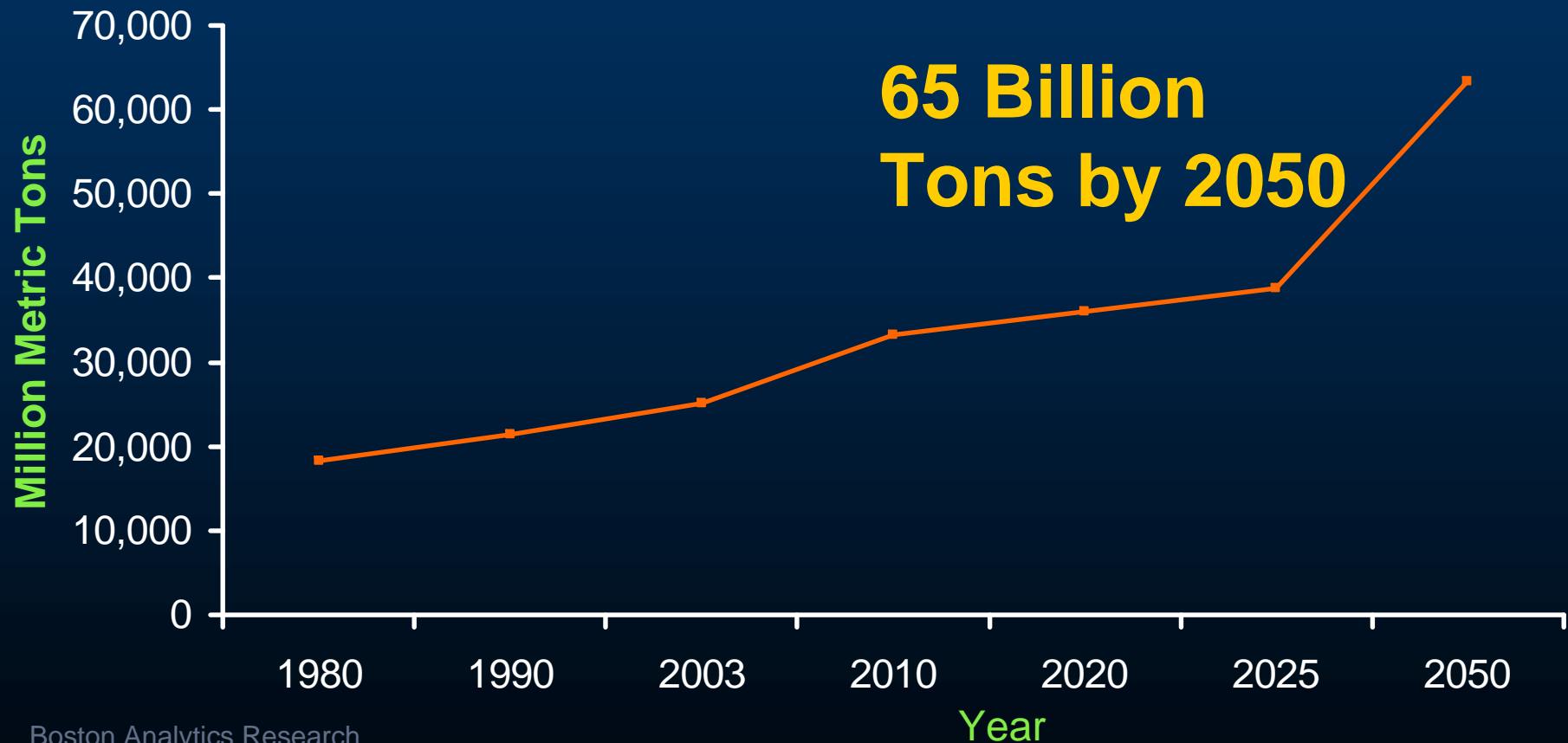

Boston Analytics Research

1. Energy Information Administration (<http://www.eia.doe.gov>)

Energy intensity has been declining with economic advancement

Energy Intensity vs. GDP per Capita of Selected countries (1980 to 2003)^{1,2,3,4}

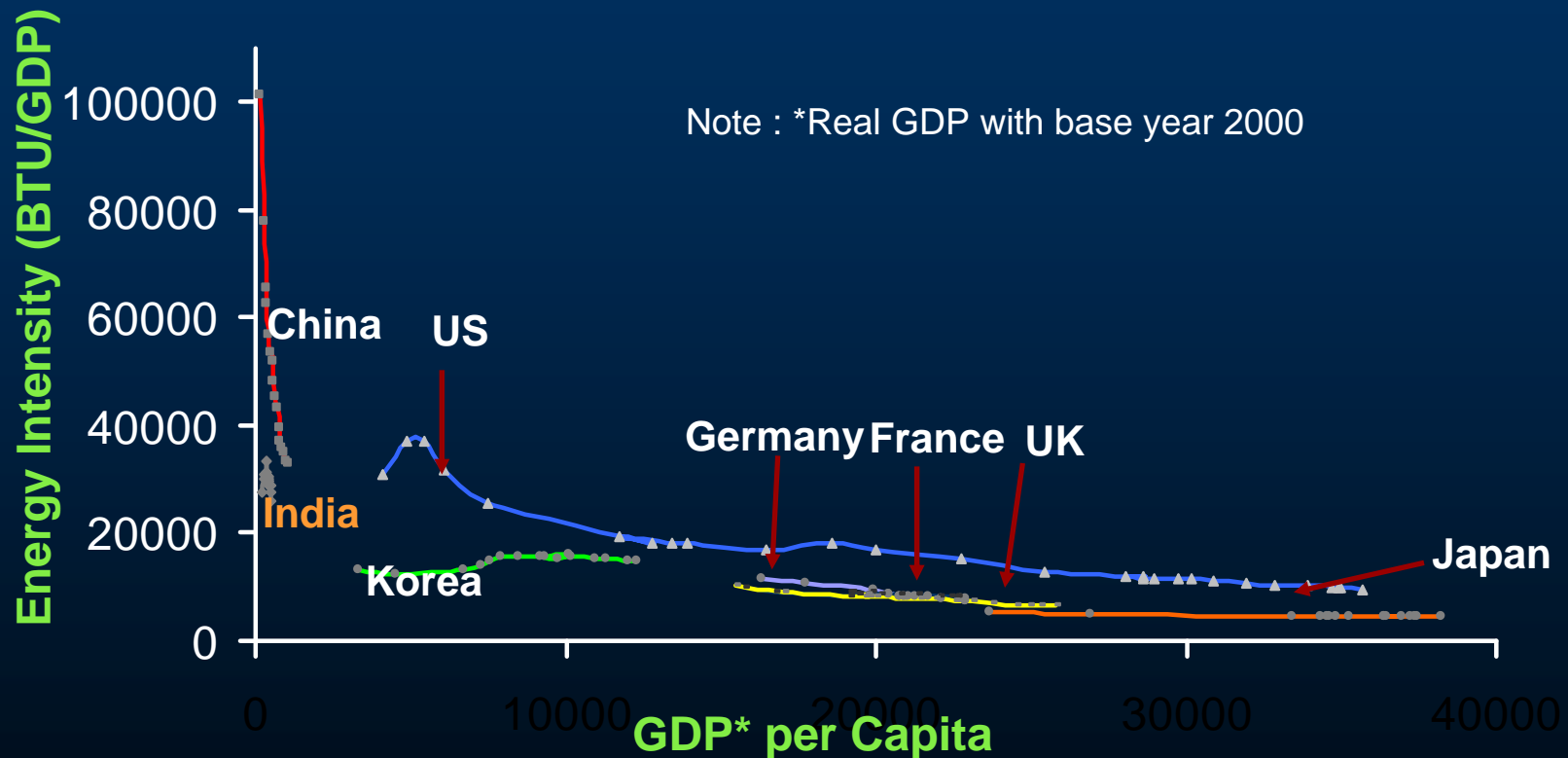

Boston Analytics Research

1. Energy Information Administration (<http://www.eia.doe.gov>)
2. <http://www.census.gov/popest/archives/1990s/popclockest.txt>
3. <http://www.uwlax.edu/ba/eco/seminars/Louis%20Johnston%20seminar%20paper%20Feb%2005.doc>
4. <http://www.gpoaccess.gov/usbudget/fy05/sheets/hist10z1.xls>

Energy Scenarios ? (Terawatt Challenge)

**Billions of people x kilowatts/person =
Terawatts**

Today: **6.3 billion people x 2.5 kW/person = 16**

With 9 billion people at Japanese energy efficiency (5kW/capita): **9 B people x 5 kW/capita = 45**

With 12 billion people at the 1970 US energy use rate of 10 kW/capita: **12 B people x 10 kW/capita = 120**

Overview of Energy Scenario

Future Natural Gas requirement of Asian countries (In BCM)

Country	2001	2010	2015	2020	2025
India	22	65	90	114	143
China	28	54	74	102	142
Japan	79	91	99	108	119
South Korea	20	28	37	43	51
Other Asia	139	153	173	198	230
Total	288	391	473	565	685

Center of Gravity of Global Economy is also shifting

Percent of GDP Distribution



Geo-Political Alliances are In Transition

Paradigm Shift

Past

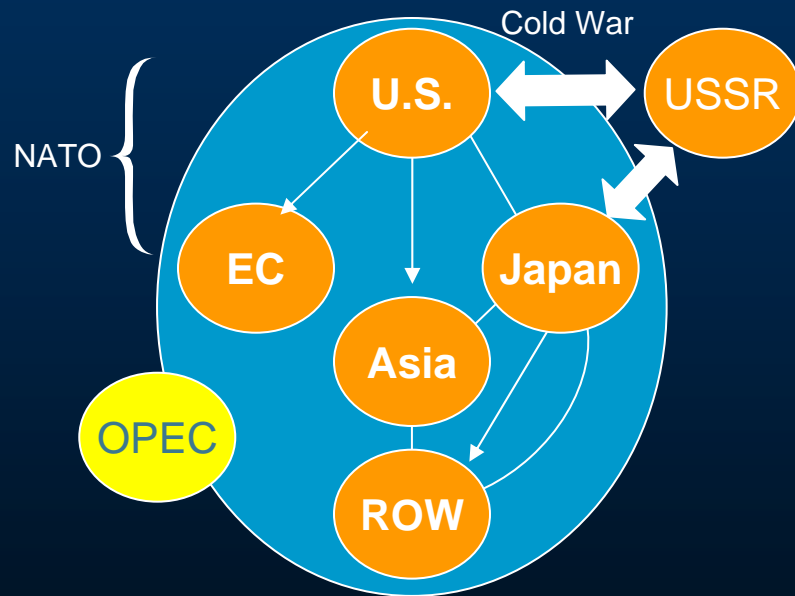

Bond by Cold War Forces of Alliances

Future

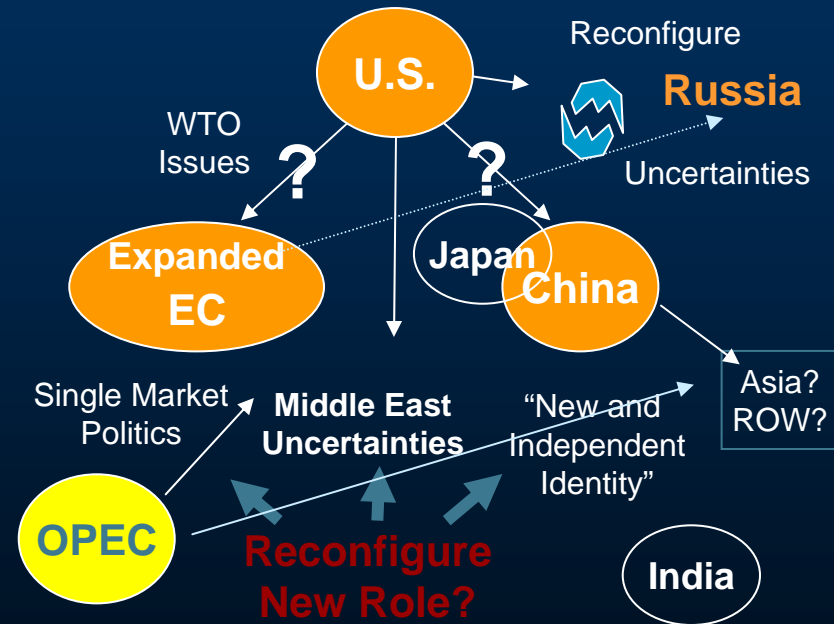

Deconstruction of Past Geopolitical Architecture

Convergence of Technologies but *How Deep?*

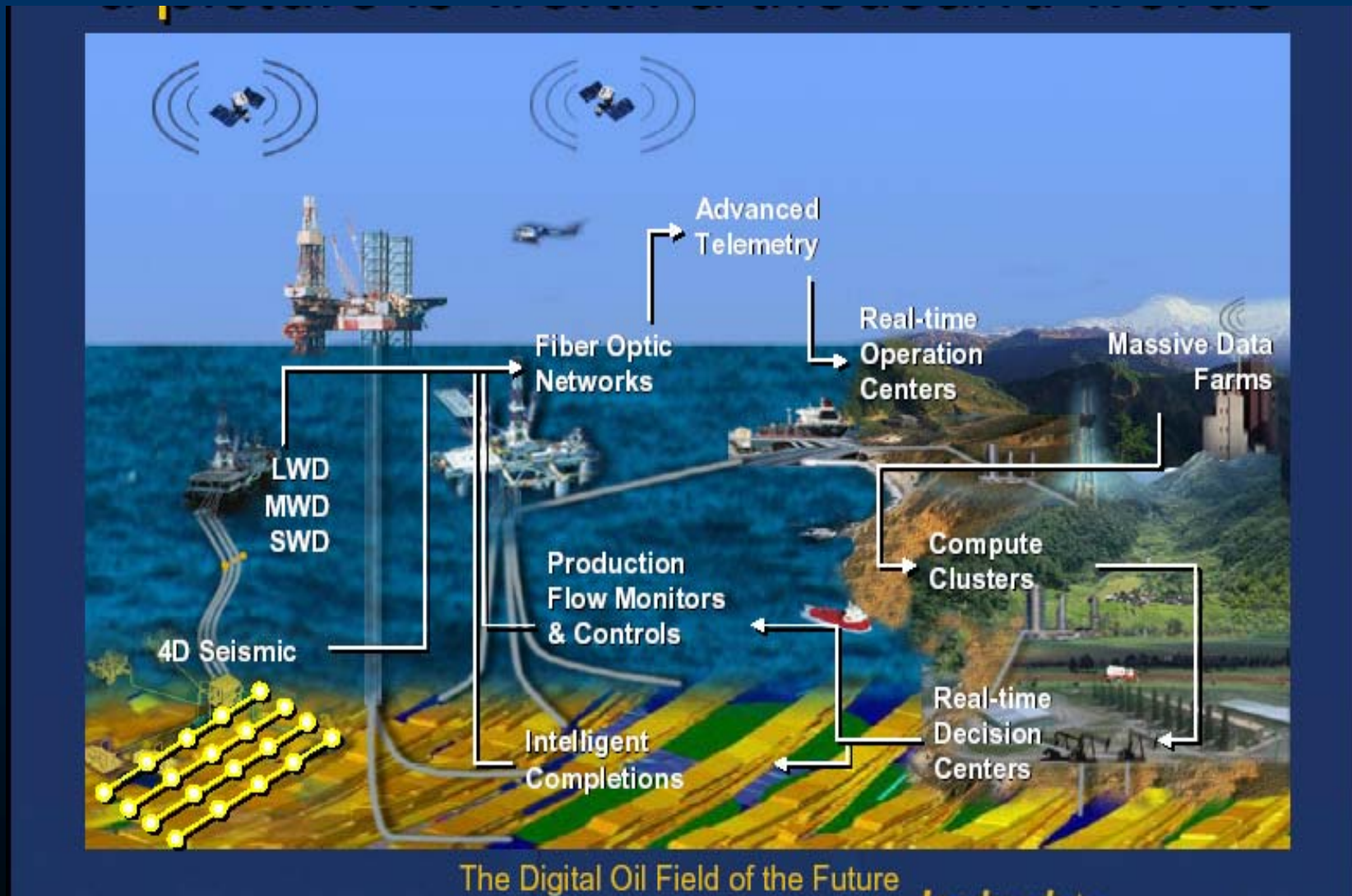

Multiple Powerful Forces making Work?

Changing Geopolitics
NOCs versus IOCs

New Technologies

Increasing Capital Intensity

Volatile Prices

Sudden events:
Terrorism, Natural Disasters

Mega Infrastructure/P&L large Stakes

Ecology Concerns

Equity

Wall Street Expectations

Interruption free Hydrocarbon infrastructure

New requirements of Digitization



Reliable, Affordable and eternal source

Four Types of Nations in the Game? *Who will win?*

Two Critical Vectors

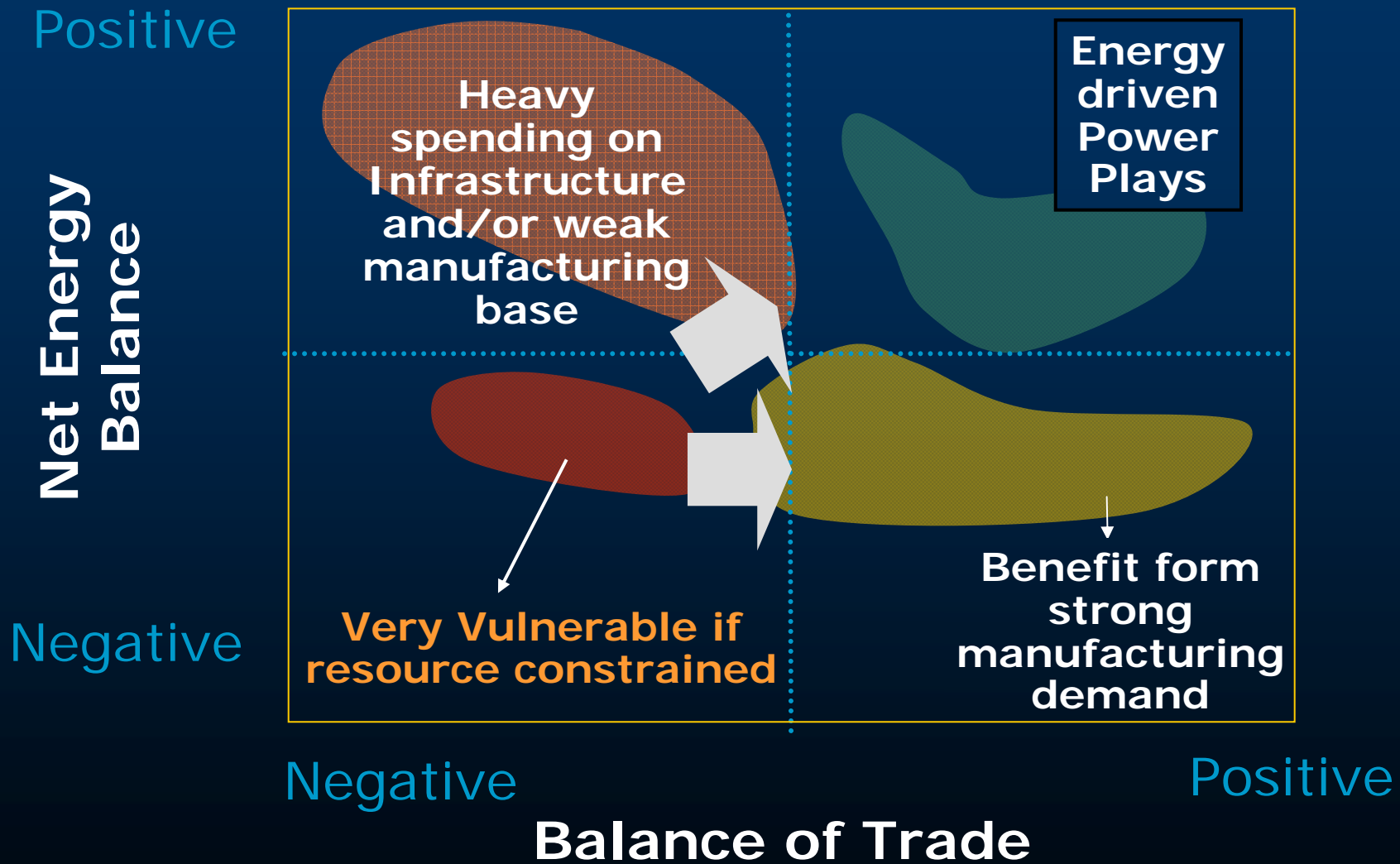

India is most vulnerable ?

Percentage Trade Balance/GDP vs. Net Energy Balance of Selected Countries (2003)^{1,2,3}

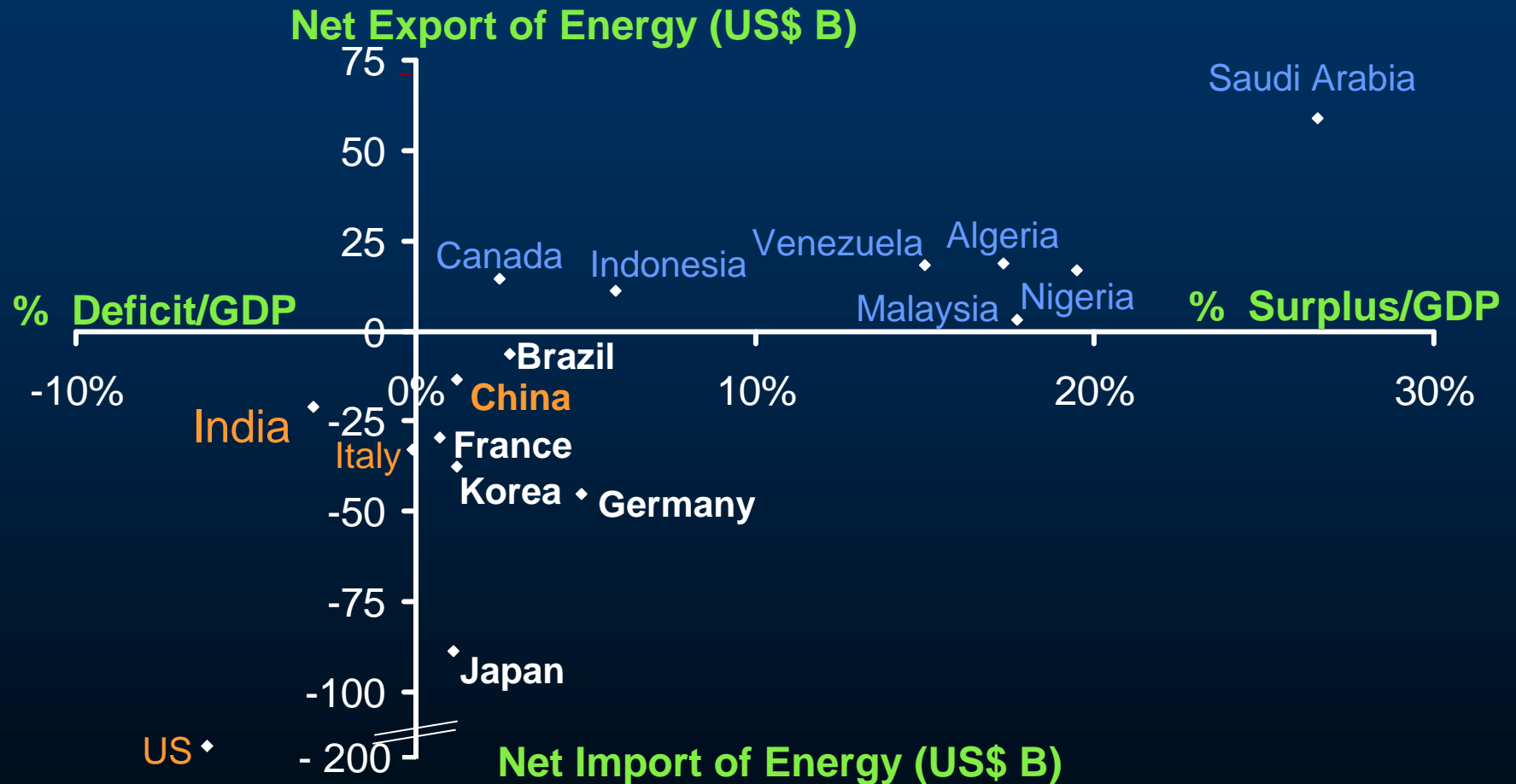

Boston Analytics Research

1. International Energy Agency (<http://www.iea.org>)
2. International trade statistics, 2004, world trade organization
3. Energy Information Administration (<http://www.eia.doe.gov>)

Contents

- *Laws of Large Numbers & Network Effect? Slow Pace of Global Energy disruption?*
- *More & better of the Same or New Game? Market Mechanisms vs Cross Border Strategic Diplomacy*
- *The Challenge: Time to rethink, repurpose and reform?*

India & US will require similar strategic moves beyond Nuclear Energy Coop

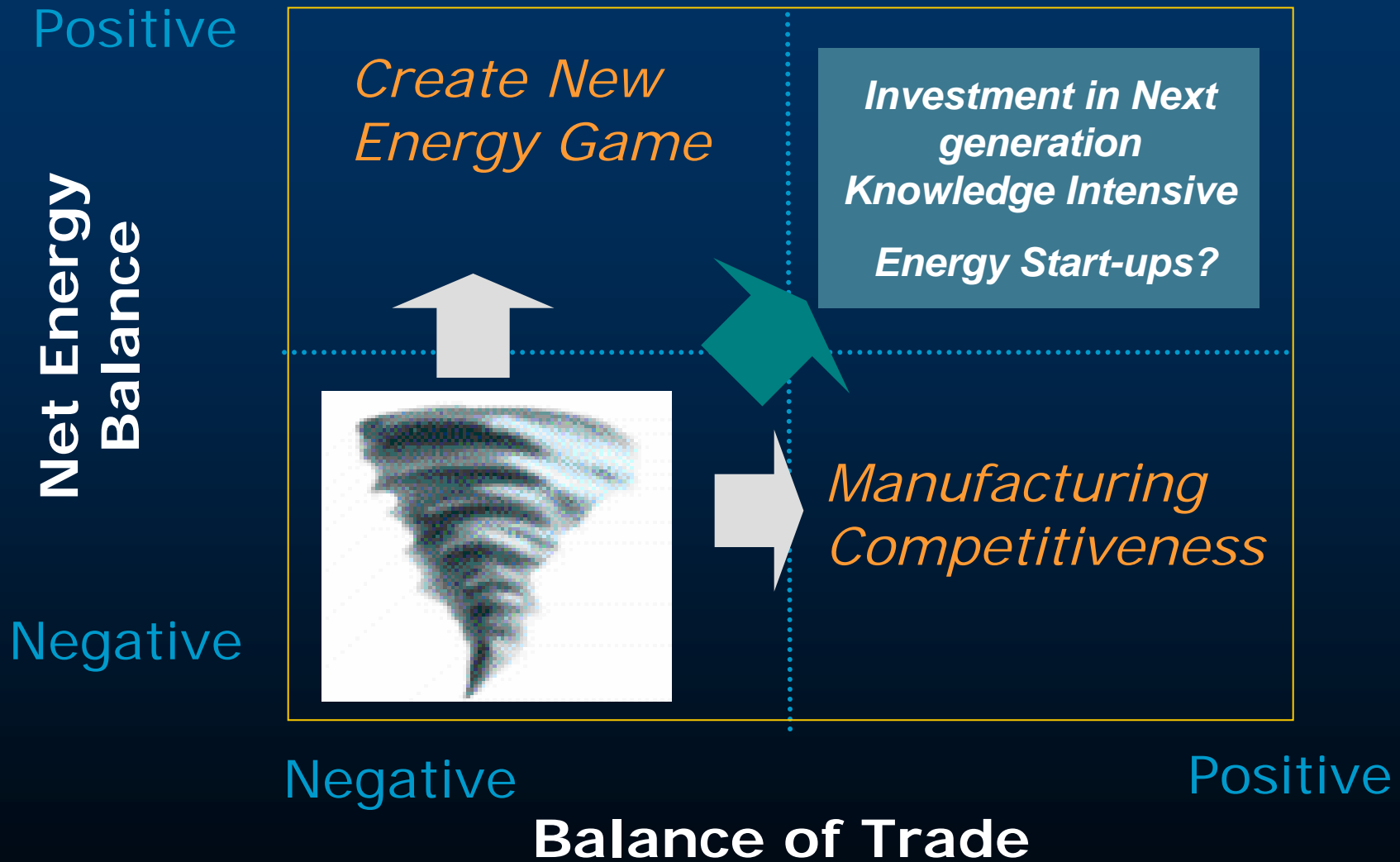

Mega Challenge = Managing a Mega Transition to avoid Mega disruption



Overcoming barriers

New Relationship of Space & Time

Supply to Fuel Unidirectional Demand



1. Concentrated Economic Growth
2. Ecological disequilibrium
3. Complex Politics of Supply Chain

Era of Multidimensional Energy Renaissance

1. Multi track models of social Experiments ?
2. New Paradigm of Knowledge Creation & Recycling ?
3. Hybrid Infrastructure ?

Contents

- *Mega World wide Energy disruption?
Laws of Large Numbers & Network Effect*
- *More & better of the Same or New
Game? Market Mechanisms vs Cross
Border Strategic Diplomacy*
- *The Challenge (7 Imperatives) : Time to
Rethink, Repurpose and Reform?*

Imperative 1 : Holistic Approach?

PROBLEMS \approx OPPORTUNITIES

Holistic Approach

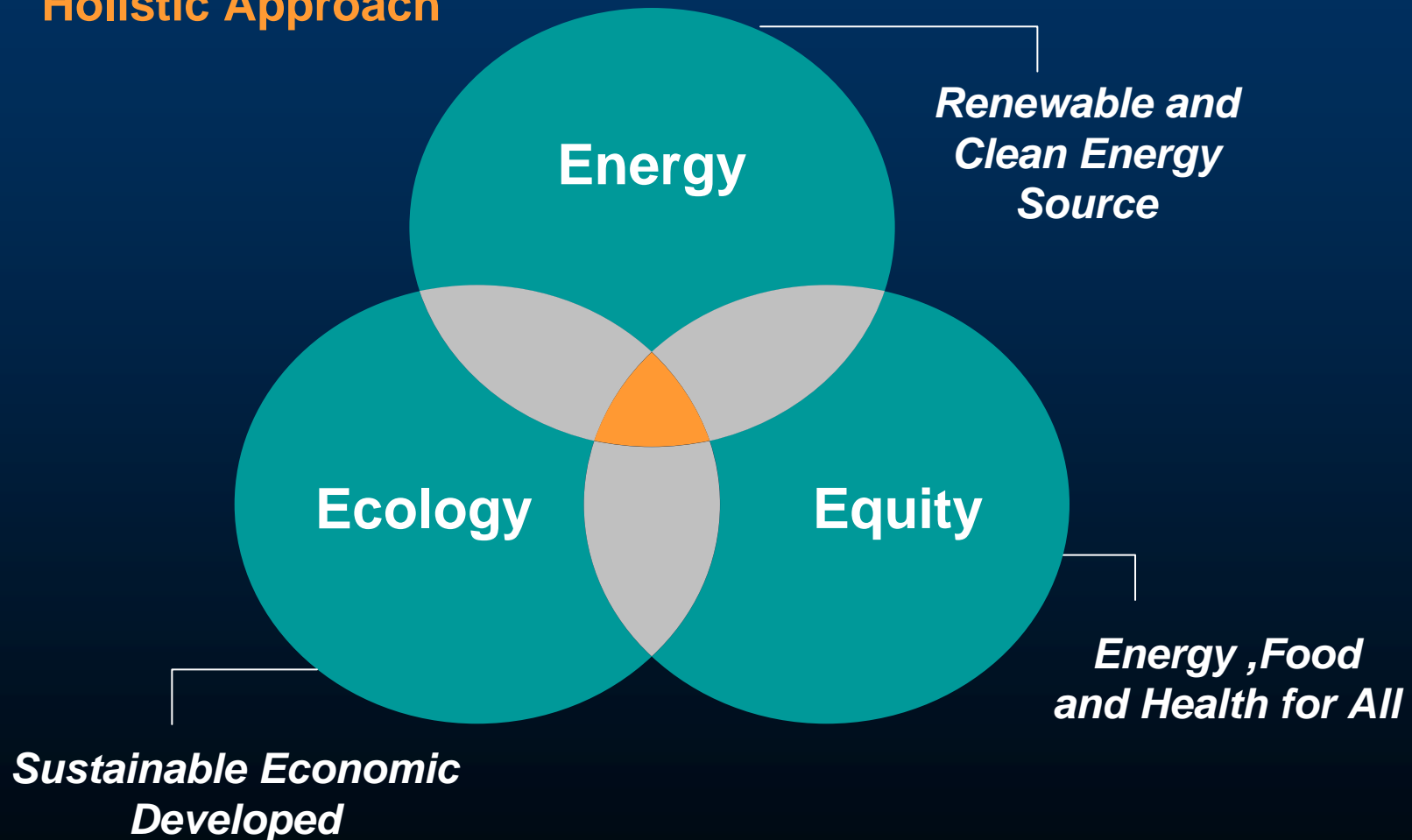

Imperative 2 : Equal amount of commitment on Supply and Demand side

Supply-Demand Dynamics of Energy Balance

Supply

- New Materials
- Precision Controls
- Nanotechnology / Catalysts
- Miniaturization
- Convergence / Broadband infrastructure

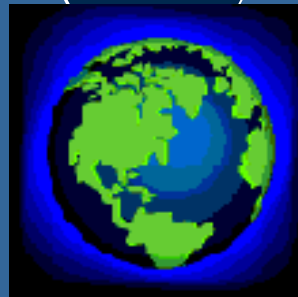

Demand

- Clean Energy
- Six Sigma Power
- Efficiency of Consumption
- Education to shape habits
- Design of living and work spaces

Imperative 3: Aggressive use of New technologies

Energy Industry Reconfiguration

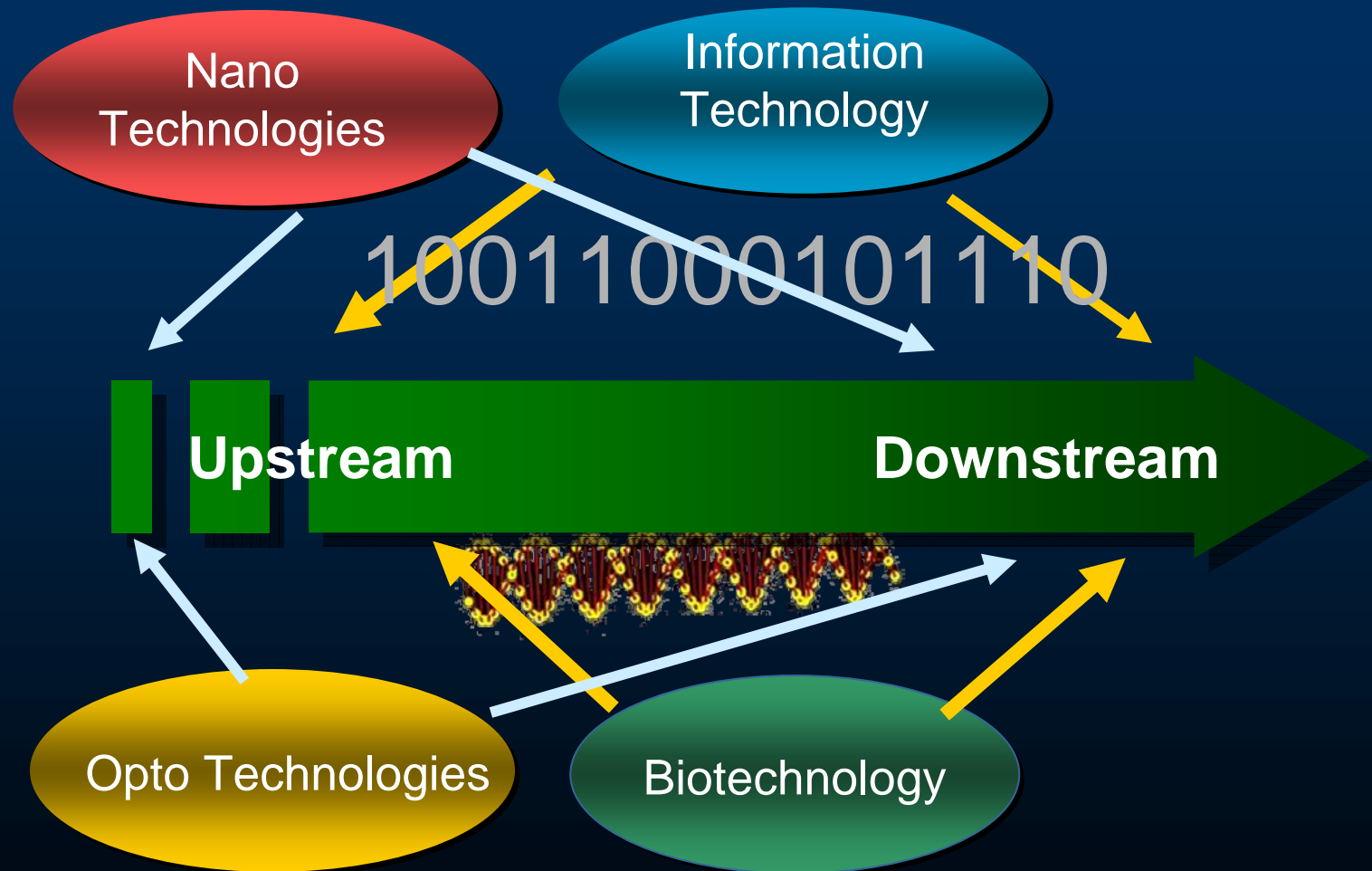

Imperative 4: Equipment efficiency?

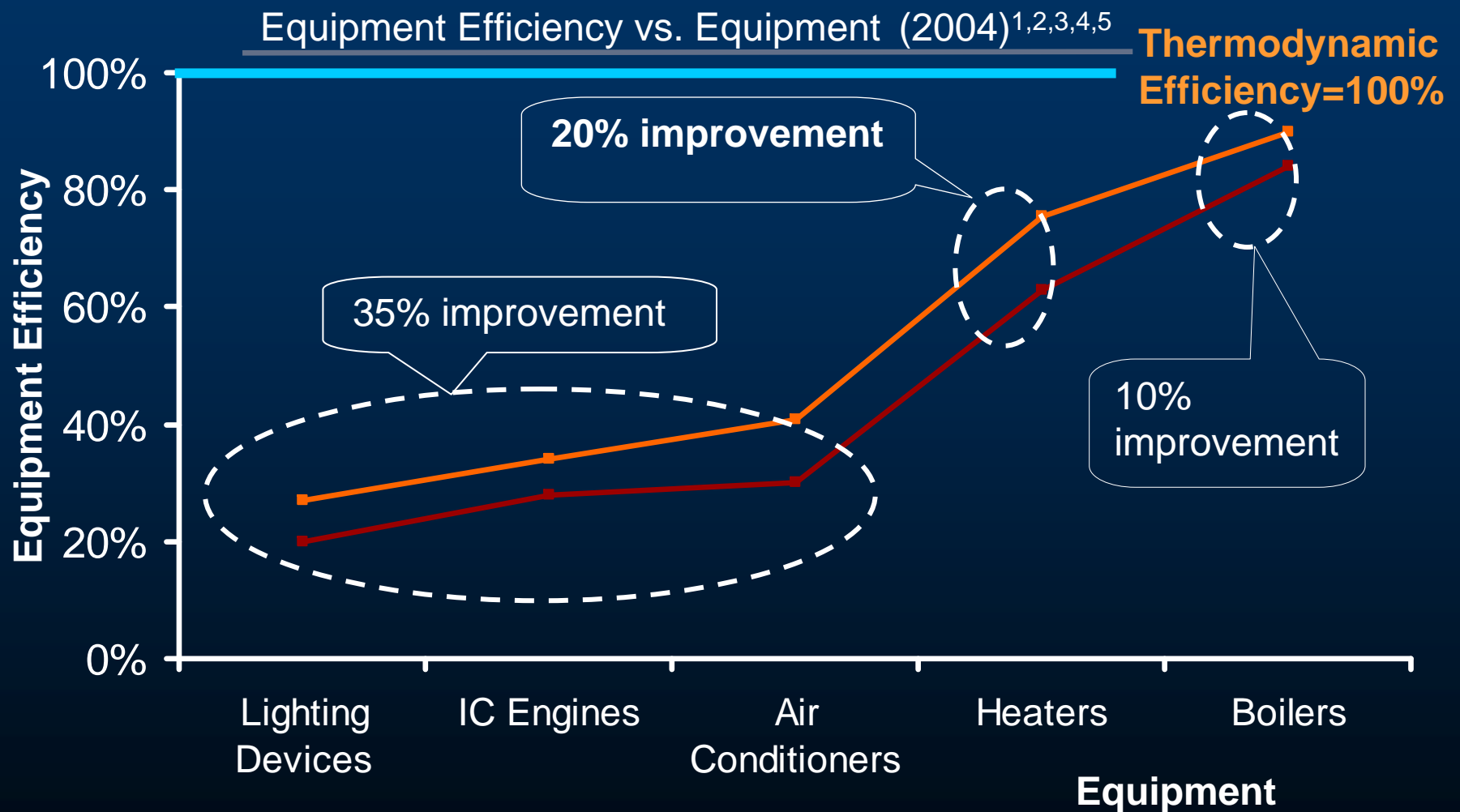

The proposed increase in efficiency could have saved ~3.4 B barrel crude oil of energy in 2004...

Energy Consumption vs. Equipment (Million Barrel Crude Oil) (2004)^{1,2}

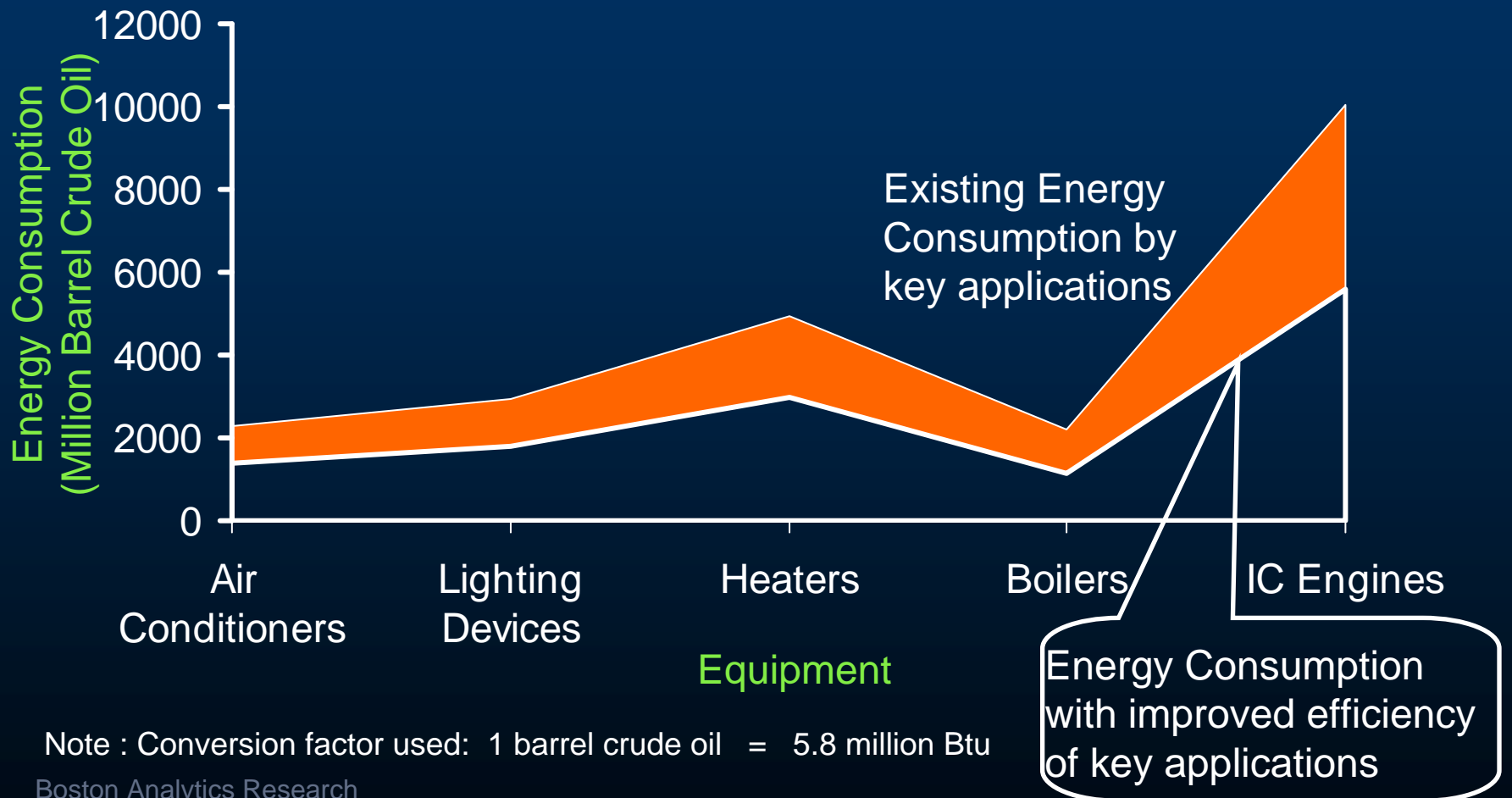

Note : Conversion factor used: 1 barrel crude oil = 5.8 million Btu

Boston Analytics Research

1. Energy Information Administration (<http://www.eia.doe.gov>)

2. http://en.wikipedia.org/wiki/Energy_conservation

India could reduce its energy consumption by as much as 45.4% in the year 2025 = 13.3 QB Btu

Energy Demand* in India in Quadrillion Btu (1980 to 2025)^{1,2}

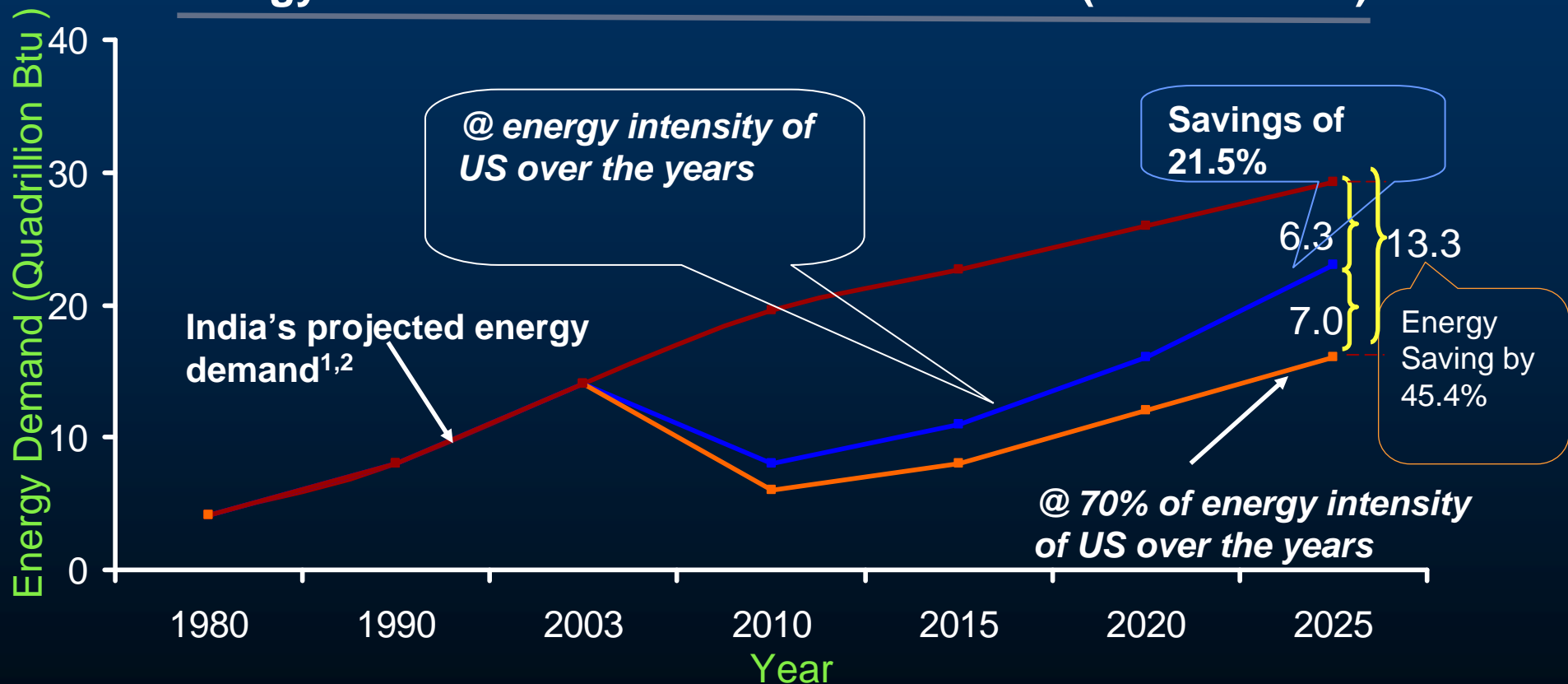

Note : Energy Demand* = (Population)*(Energy Intensity)*(GDP per Capita)

Boston Analytics Research

1. Energy Information Administration (<http://www.eia.doe.gov>)

2. "World Energy and Economic Outlook", Energy Information Administration/ International Energy Outlook 2005

Reduction in energy intensity could reduce world energy demand by 14% in 2025

World Energy Demand in Quadrillion Btu (2025)¹ :If Energy Intensity is Reduced in Selected Regions

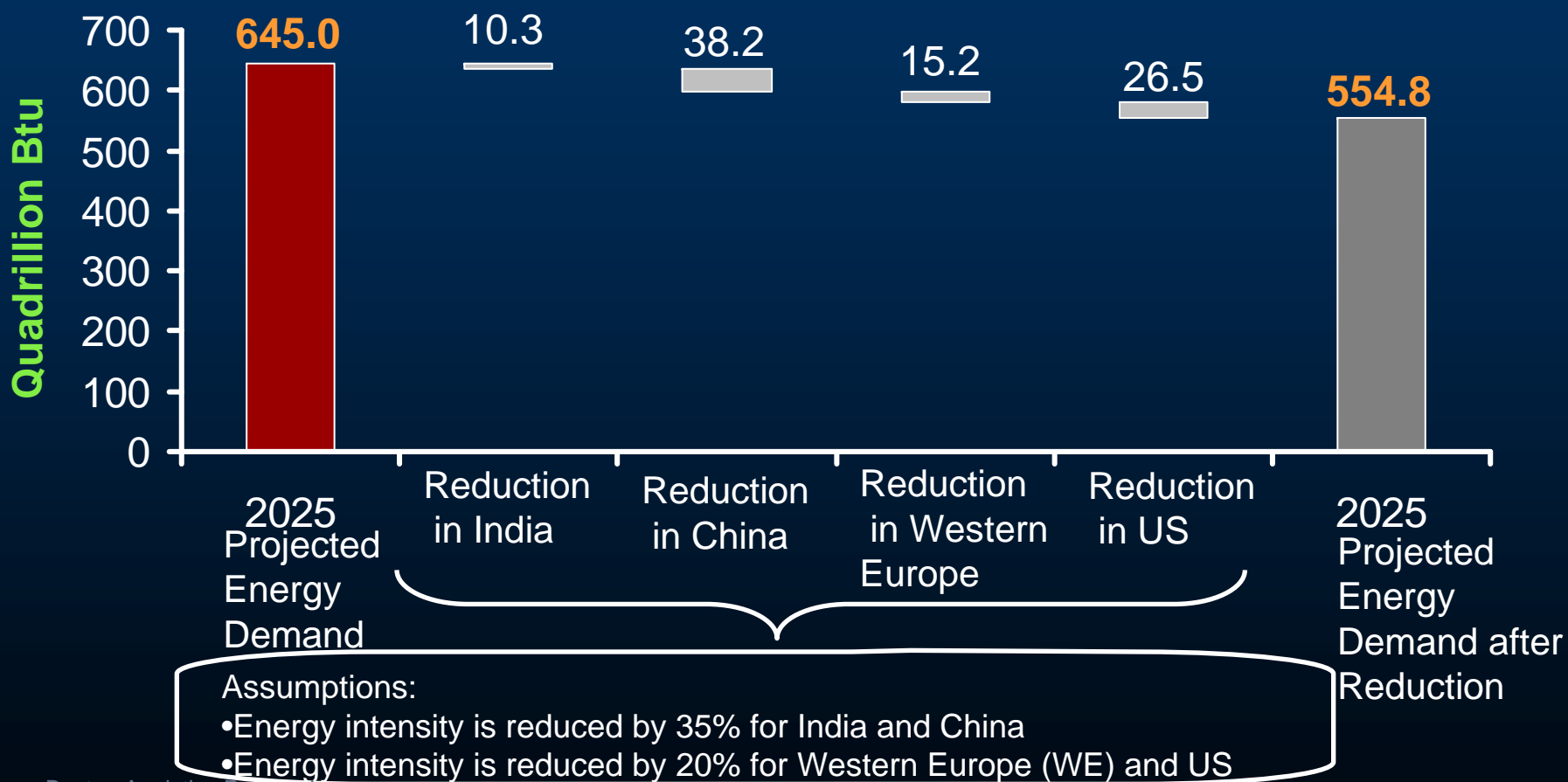

Boston Analytics Research

1. Energy Information Administration (<http://www.eia.doe.gov>)

2. "World Energy and Economic Outlook", Energy Information Administration/ International Energy Outlook 2005

Imperative 4 : Large Scale Engineering systems thinking....Vision of NextGen Distributed Power Infrastructure

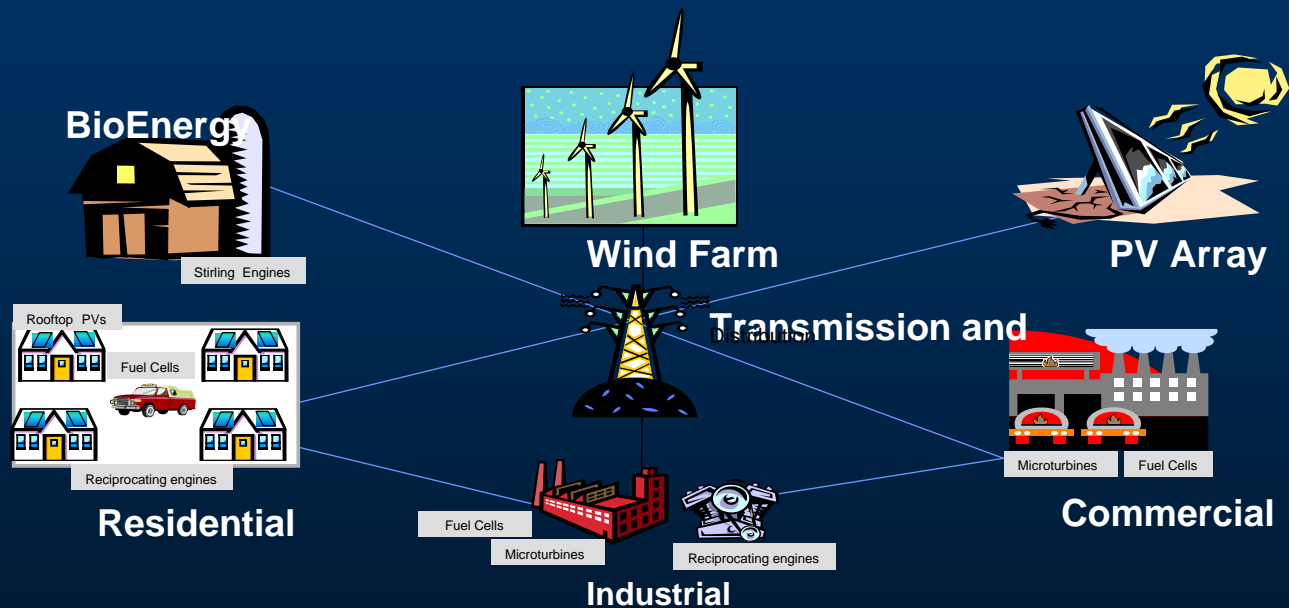

The Virtual Power Plant

- *Aggregates the output of thousands of micropower technologies*
- *Peak shaving becomes power trading on the wholesale market*
- *Coordination and control through a new communications infrastructure*

Engineering Systems Advanced Solid Modeling Capability

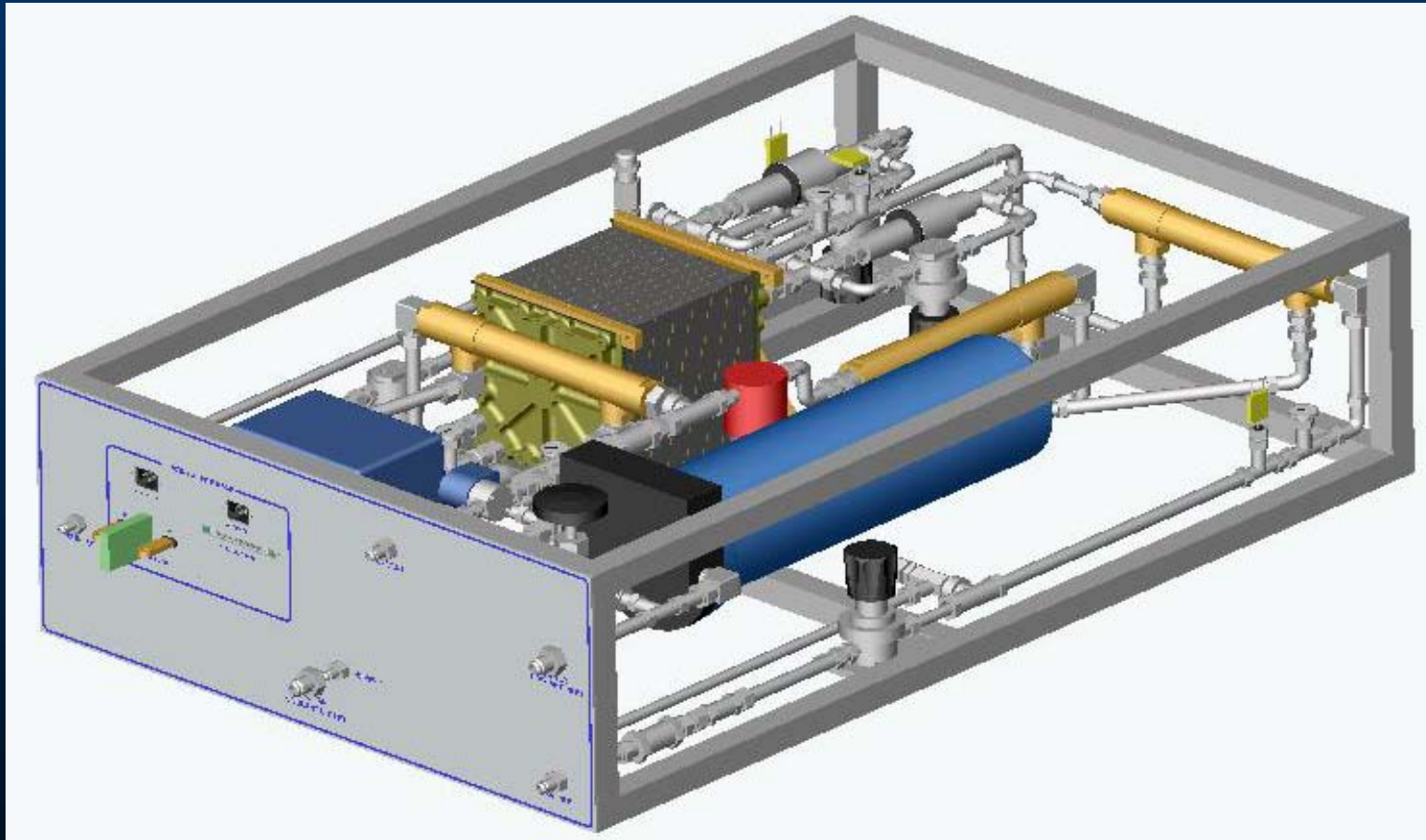

Engineering Tools Include Autocad, Solidworks, Thermal Analysis System, Fortran, C++

Imperative 5 : New Accounting for Depletion and Ecology

Comparison of Average Electricity Generation Cost*
(\$cents/KWh)^{1,2,3}

Capital Cost* (\$/KW)^{1,2,3}

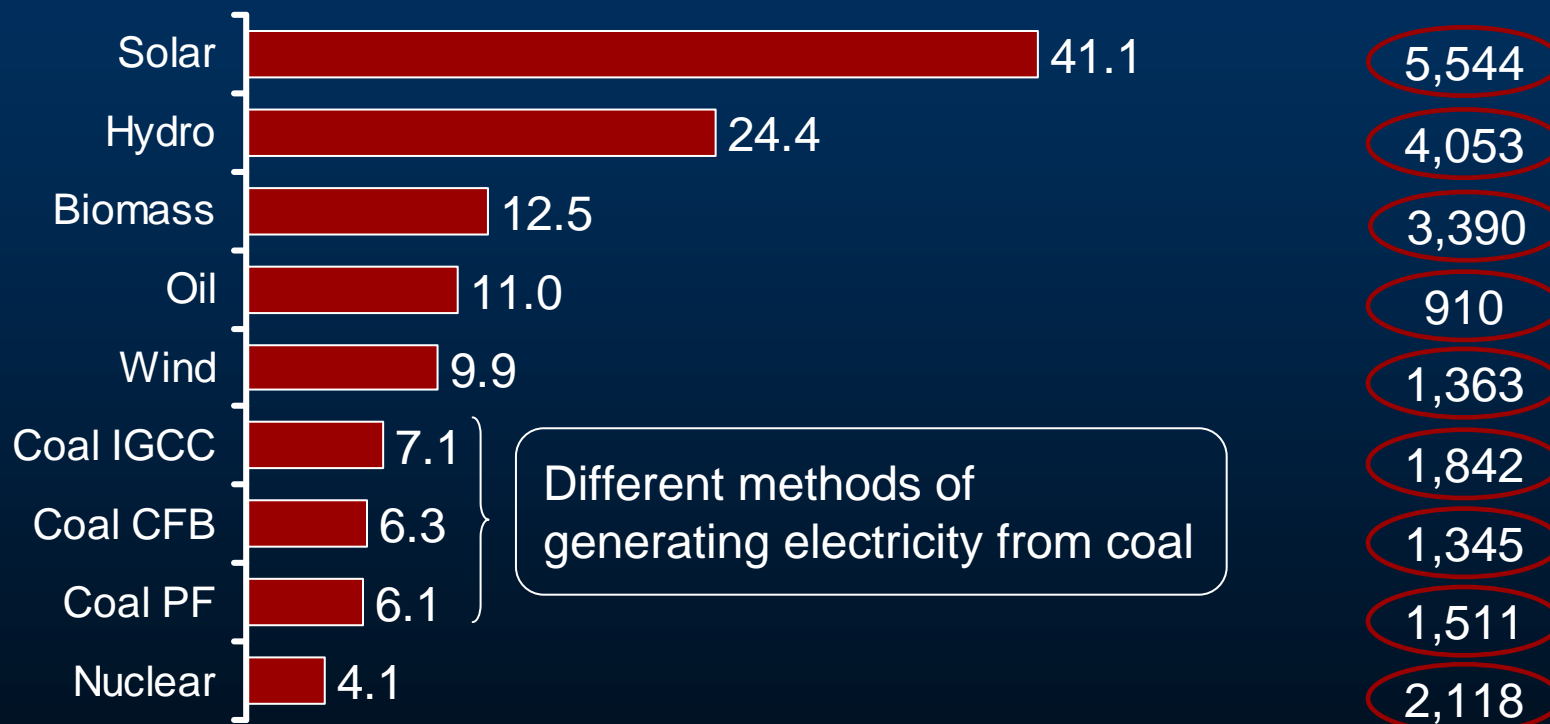

Note : *These are only indicative figures. Actually, electricity generation cost varies across different territories as per the environmental and technological scenario.

Boston Analytics Research

1. "The Cost of Generating Electricity", Royal Academy of Engineering, March 2004 (213.130.42.236/wna_pdfs/rae-summary.pdf)

2. "Powering the Nation", Parsons Brinckerhoff Ltd, March 2006 (<http://www.pbpower.net/inprint/pbpubs/powerthenation/powerthenation.htm>)

3. "Solar Energy in SGM, Renewable Energy Modeling Series", Allen Fawcett, Copyright © 2006 Partha S. Ghosh & Boston Analytics. All rights reserved.

Electricity generation dynamics

Comparison of Average Electricity Generation Cost (\$cents/KWh)¹

Capital Cost (\$/KW)^{2,3,4,5,6,7}

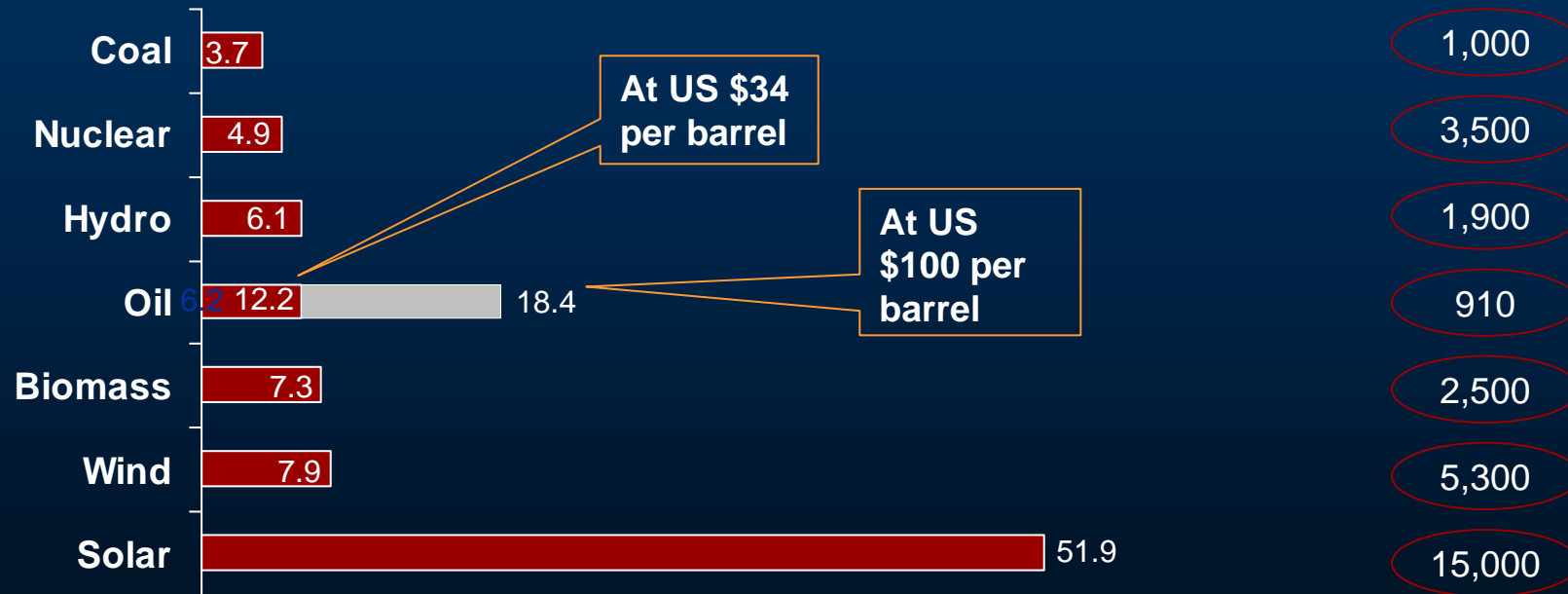

Imperative 6: Not Either Or, Unification

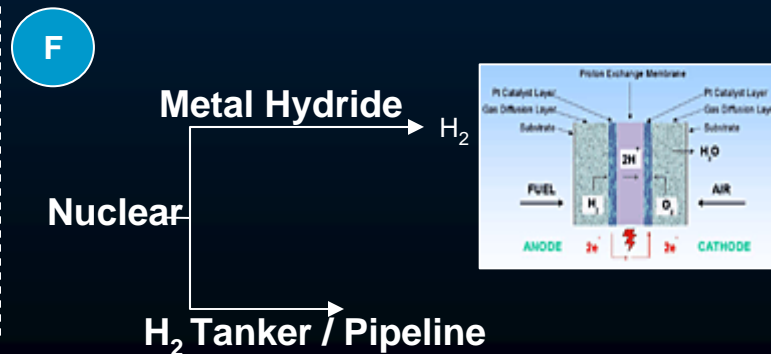
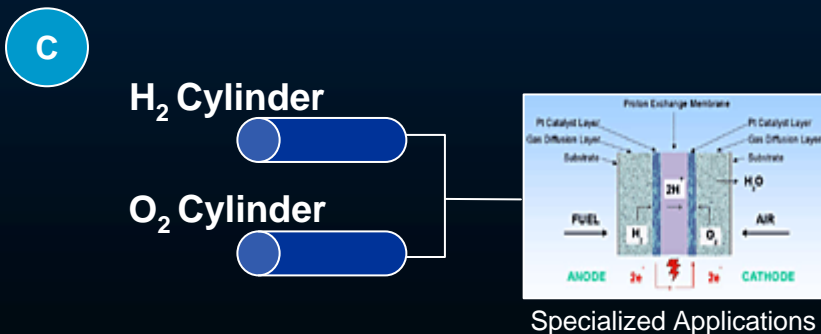
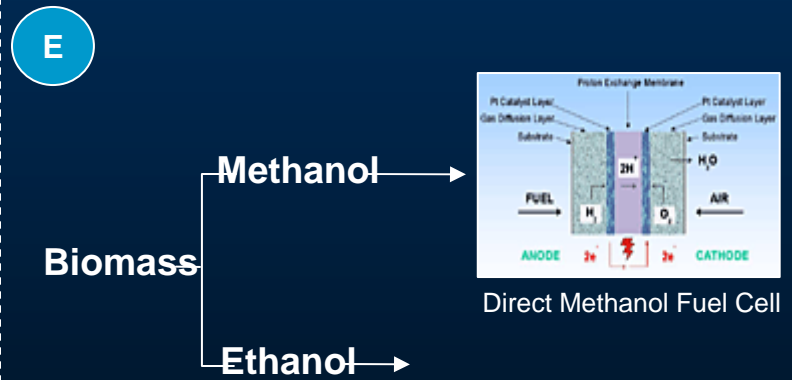
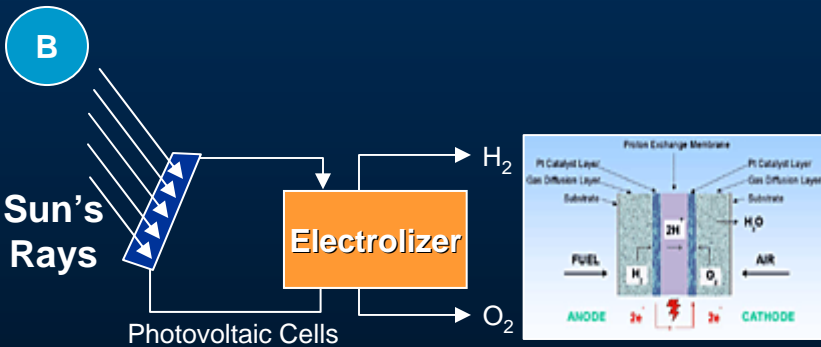
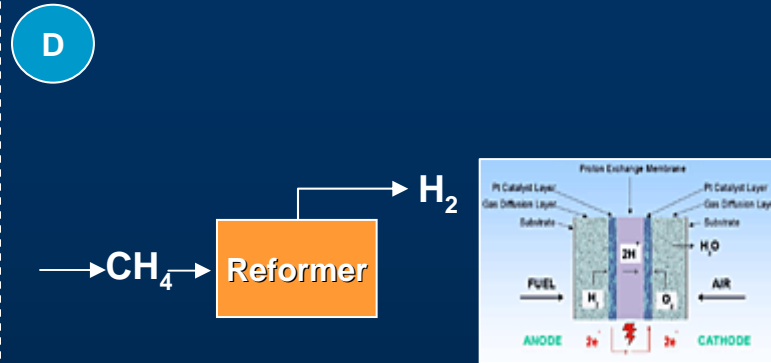
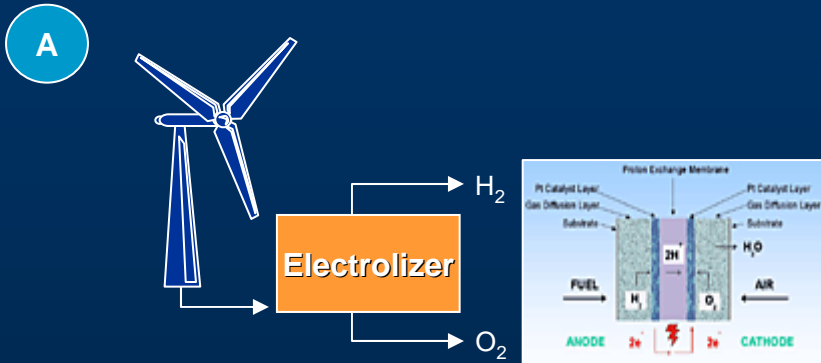

Imperative 7: Collaborative Problem Solving & Synthetic Approach

Competing Technologies and Barriers to Commercialization



DMFC
PEMFC
SOFC

Size
Cost
Heat

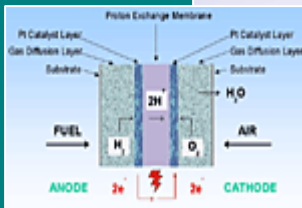
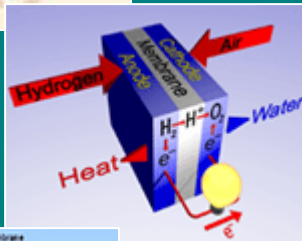

MCFC
PAFC

Reliability
Efficiency
Fuel Storage
Fuel Type

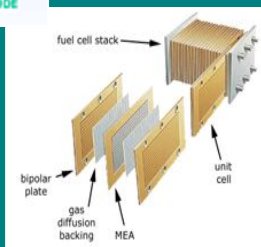

Automotive
Oil & Gas



Utility



Consumer Electronics
Specialty Chemical



Plastics
Raw Material



Mining



Nanotechnology

"Pure Play" Fuel Cell



Uncertain Market Opportunities



Portable
Devices



Military
Applications



Transportation



Stationary
Power



Shape of things to come...

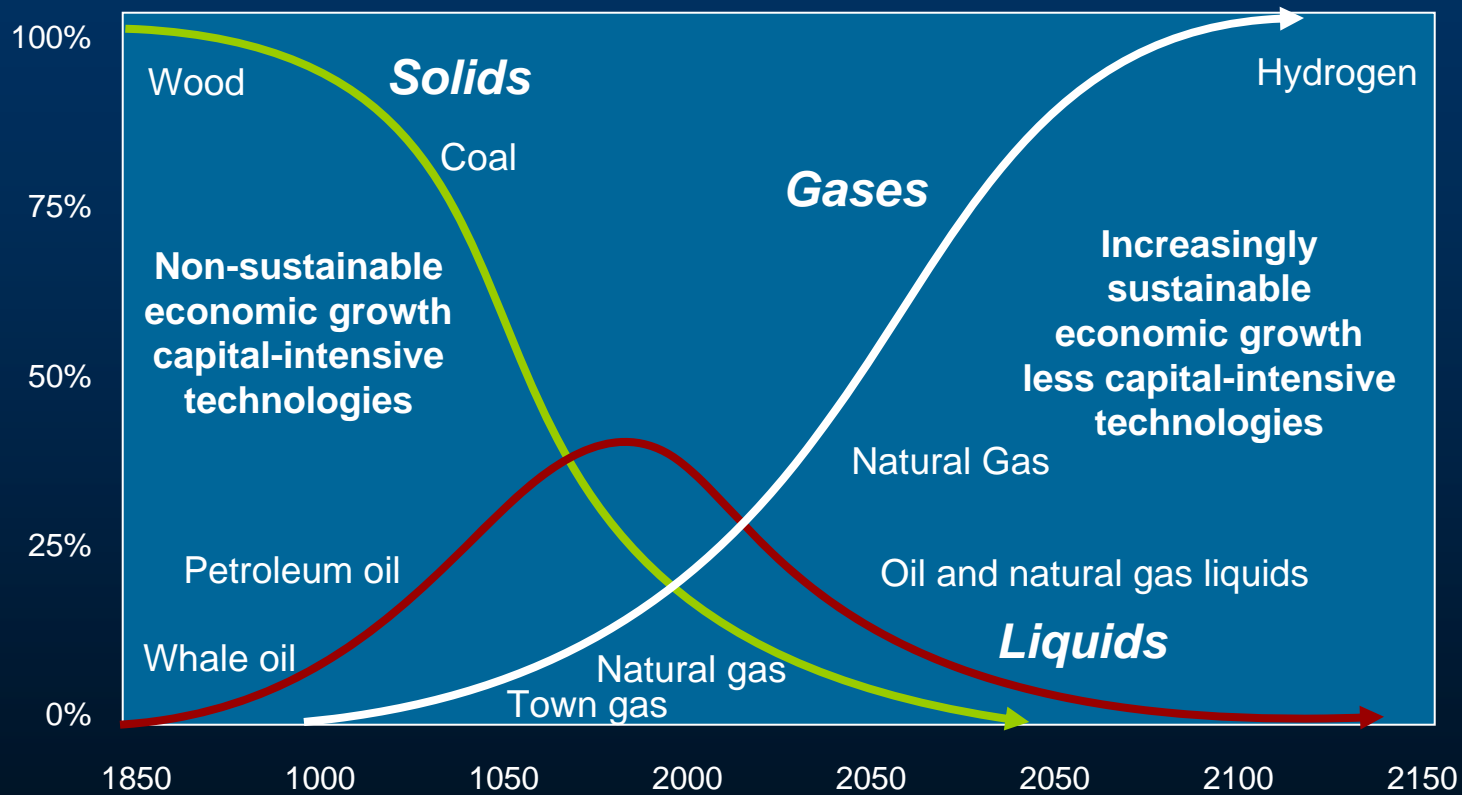

...beyond carbon?

Risk Management Capacity Will Need to Be Fundamentally Reviewed

Business System (Simplified)

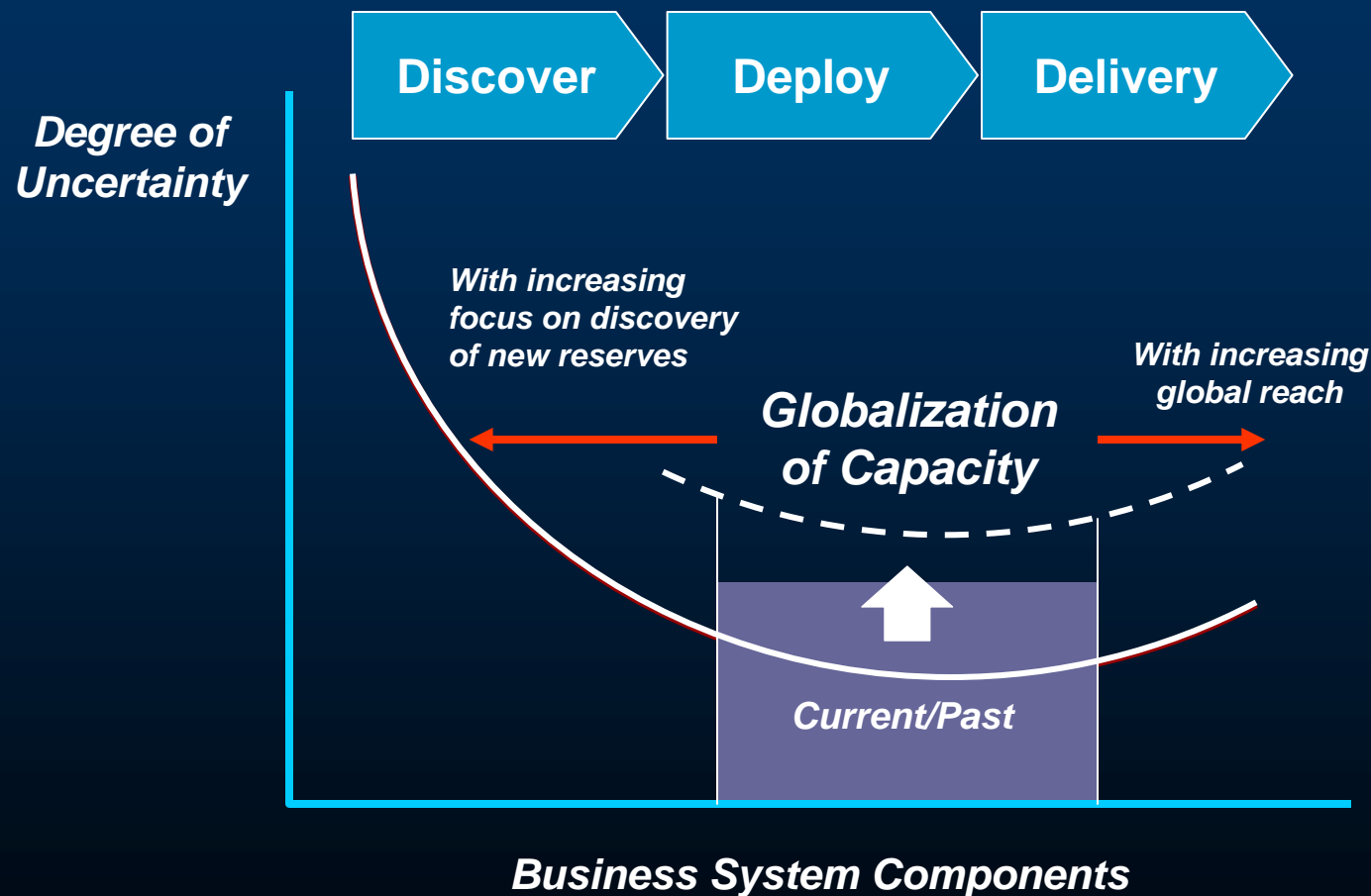

Leadership Capacity ? *Across Nations & Across the Lines of Enquiry*

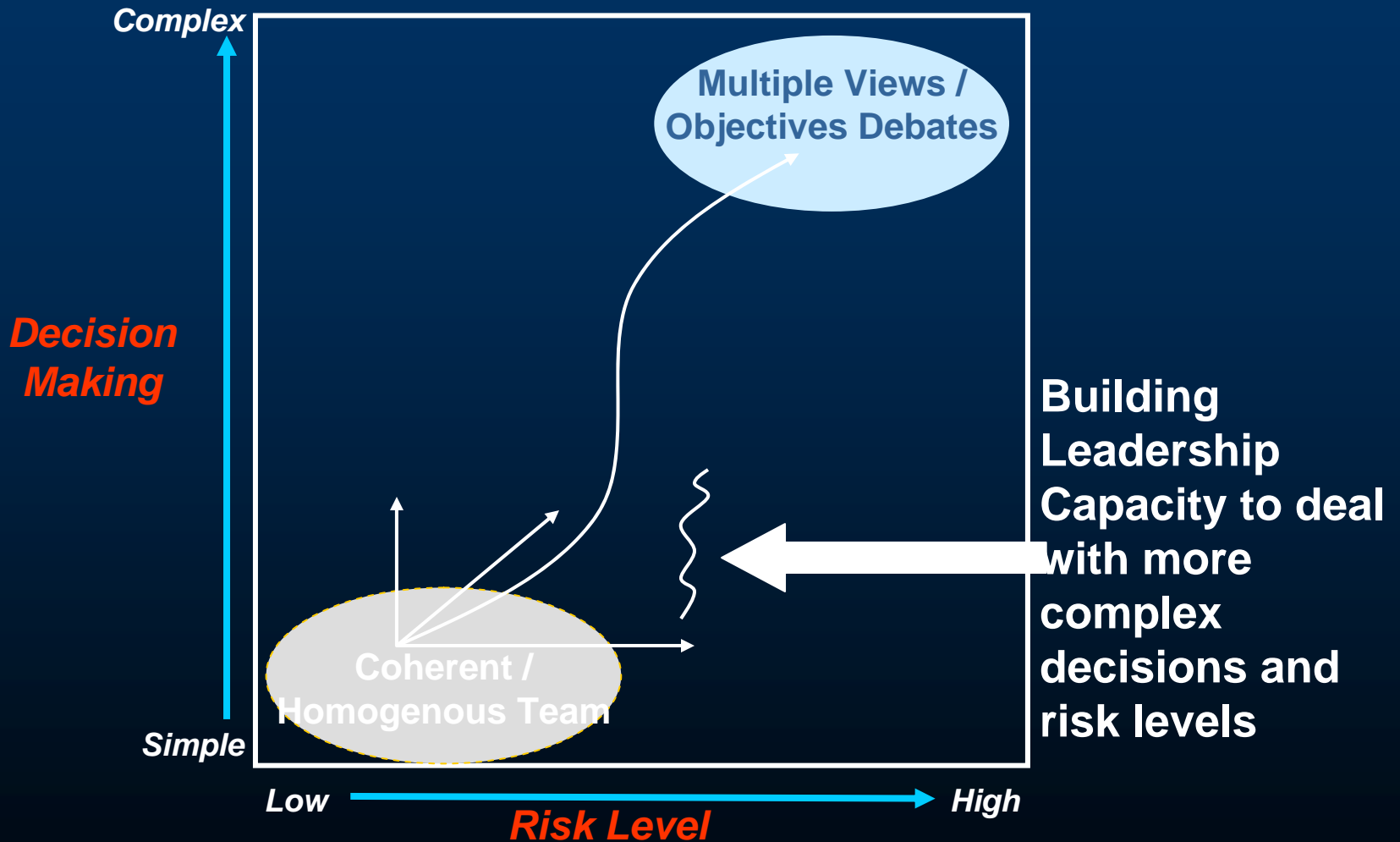

A Reminder: *Navigating through Paradigm shift = Harnessing the Energy of a Tornado*

Economic Impact



The Journey forward . . .



**Toward a New
Integrated
Vision for
Intelligent
Holistic Energy
Plays**

Three layers of Energy Development

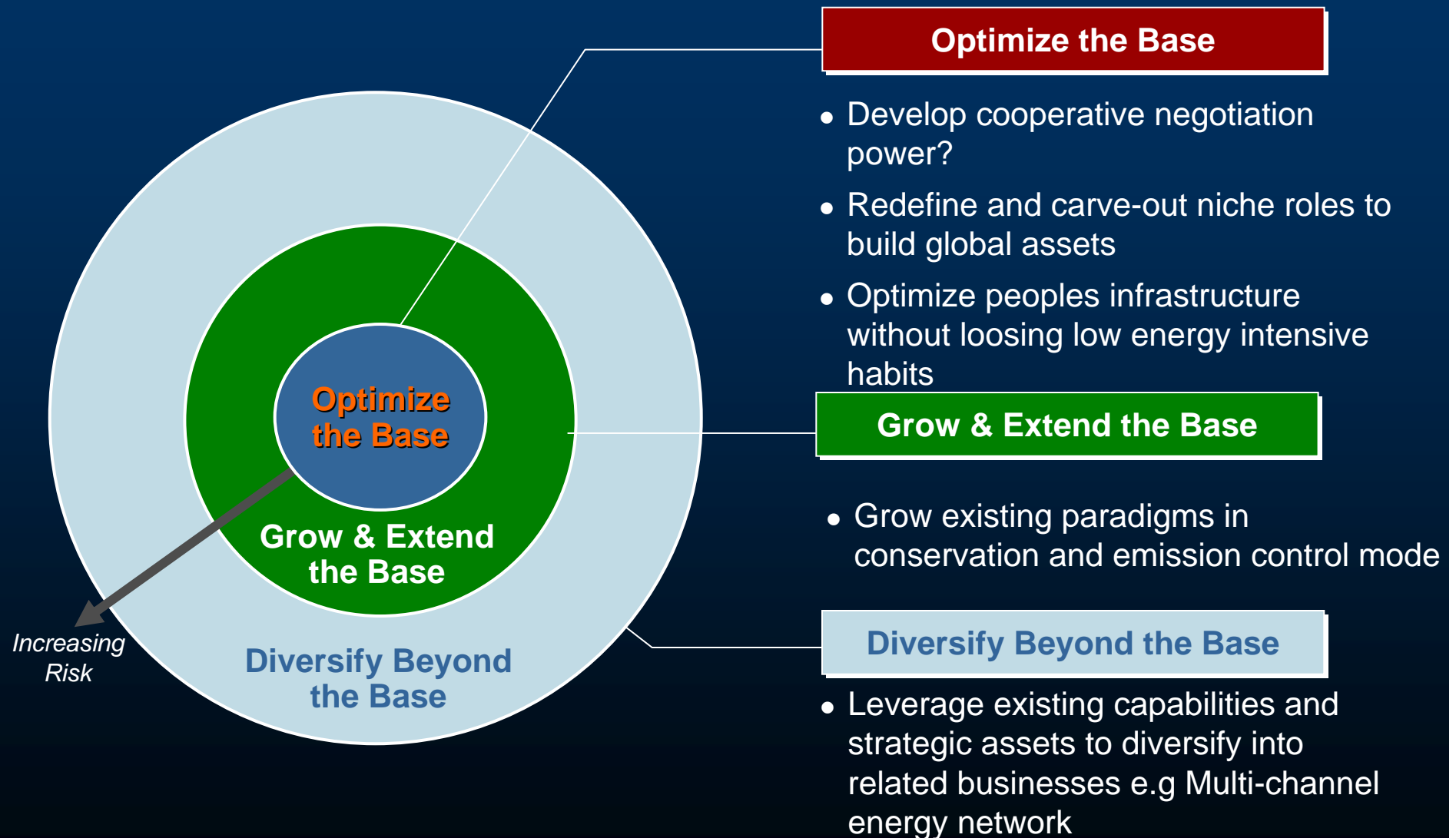

Last 5,000 Years...

.....Future

Possibilities..

Economics of Linear

Mechanics: Extraction, Exploitation and Experimentation

Economics of Closed Loop Harmony

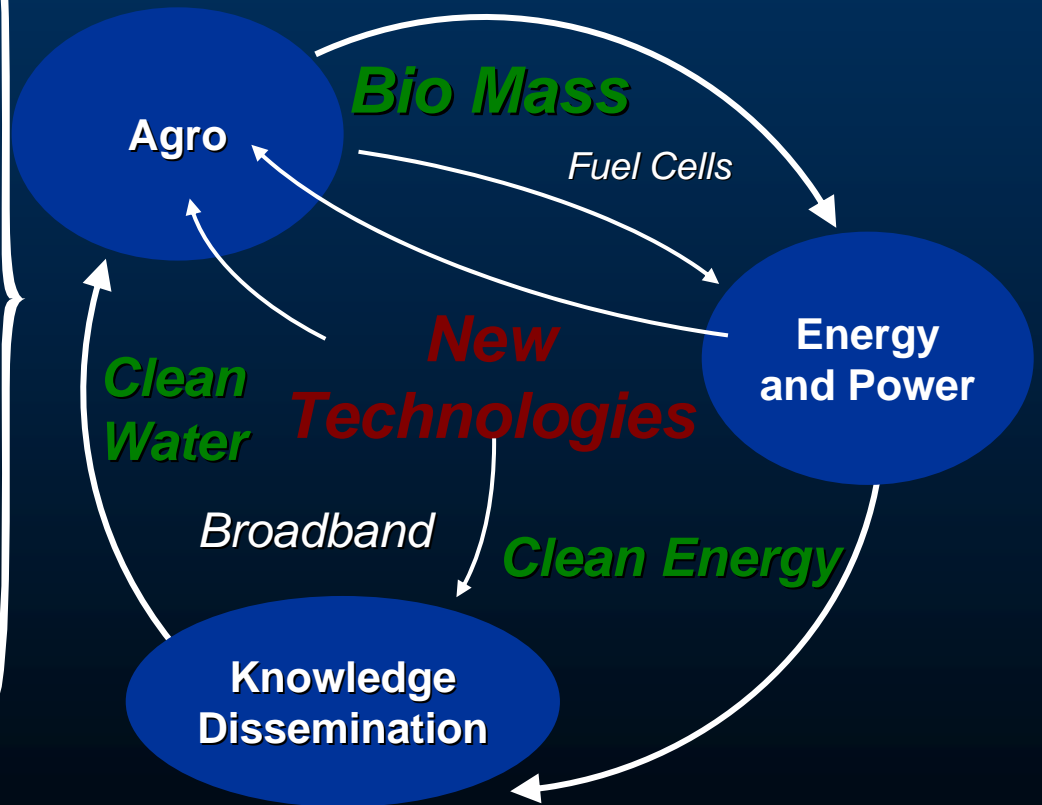
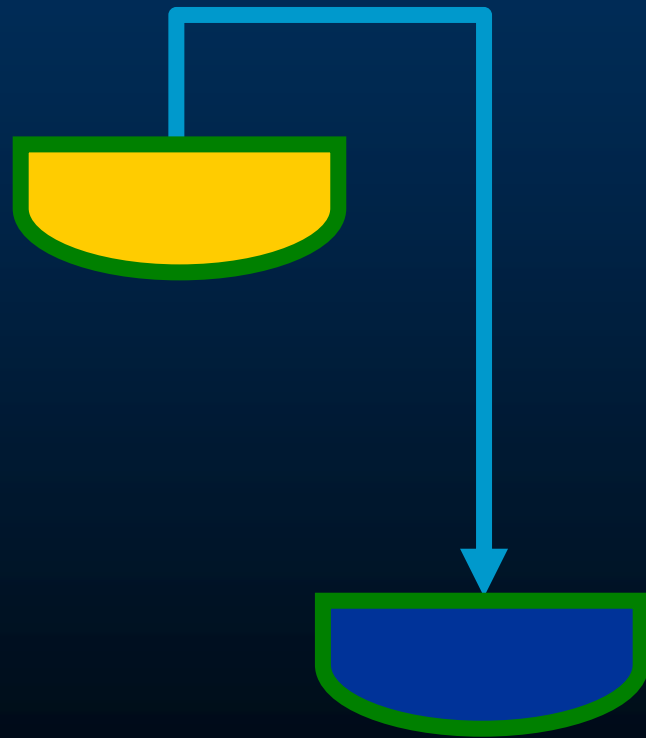

.. To Rekindle the Sprit of Enquiry

